



A 1632 eMobility Analyser

Basic user guide

Version 1.1.4



Distributor:

Manufacturer:
METREL d.d.
Ljubljanska cesta 77
1354 Horjul
Slovenia

web site: <http://www.metrel.si>
e-mail: metrel@metrel.si

© 2019 METREL



Mark on your equipment certifies that this equipment meets the requirements of the EU (European Union) concerning safety and electromagnetic compatibility regulations.

No part of this publication may be reproduced or utilized in any form or by any means without permission in writing from METREL.

Table of contents

1	INTRODUCTION	6
2	THE A 1632 EMOBILITY ANALYSER	7
2.1	CONTENTS OF SET	7
2.2	USE CASES	8
2.3	EVSE TESTING	10
2.4	MODE 2 EV CABLE SAFETY TESTING	10
3	STANDARD EN 61851-1	11
3.1	EV CONNECTOR TYPES	11
3.1.1	<i>Type 1</i>	11
3.1.2	<i>Type 2</i>	12
3.1.3	<i>Type 3</i>	12
3.1.4	<i>Type 1 CCS</i>	13
3.1.5	<i>Type 2 CCS</i>	14
3.1.6	<i>CHAdEMO</i>	15
3.2	CHARGING CASES EXPLAINED	16
3.2.1	<i>Charging Case A</i>	16
3.2.2	<i>Charging Case B</i>	16
3.2.3	<i>Charging Case C</i>	17
3.3	CHARGING MODES EXPLAINED	17
3.3.1	<i>Charging Mode 1</i>	17
3.3.2	<i>Charging Mode 2</i>	18
3.3.3	<i>Charging Mode 3</i>	18
3.3.4	<i>Charging Mode 4</i>	19
3.4	CHARGING STATES	19
3.5	MAX. CHARGING CURRENT (I.E. CHARGING SPEED)	20
4	RECOMMENDED INSPECTIONS AND INSPECTION INTERVALS	22
4.1	INSPECTION OF EVSE	22
4.2	INSPECTION OF MODE 2 EV CABLE	22
4.3	INSPECTION OF MODE 3 EV CABLE	23
4.4	INSPECTION INTERVALS	23
5	SETTINGS ON THE A 1632 AND MASTER INSTRUMENT	24
5.1	PAIRING THE A 1632 EMOBILITY ANALYSER WITH THE MASTER INSTRUMENT	24
5.2	SETTING THE A 1632 EMOBILITY ANALYSER OPERATING MODES	25
6	PERFORMING MEASUREMENTS	26
6.1	EVSE CHARGING STATION TESTING	27
6.1.1	<i>Manual functional and diagnostic EVSE testing</i>	28
6.1.2	<i>Semi-automated functional and diagnostic EVSE testing</i>	30
6.1.3	<i>Automated electrical safety EVSE testing</i>	31
6.2	MODE 2 EV CABLE TESTING	33
6.2.1	<i>Manual functional Mode 2 EV cable testing</i>	34
6.2.2	<i>Manual diagnostic Mode 2 EV cable testing on the input side</i>	35
6.2.3	<i>Manual diagnostic Mode 2 EV cable testing on the output side</i>	35

6.2.4	<i>Semi-automated functional and diagnostic Mode 2 EV cable testing on the output side</i>	35
6.2.5	<i>Manual electrical safety testing of Mode 2 EV cable</i>	36
6.2.5.1	Continuity measurement (R low 200 mA)	36
6.2.5.2	Insulation measurement (R iso)	37
6.2.5.3	RCD (IC-CPD / PRCD S+) measurement	38
6.2.5.4	Leakage current measurement	39
6.3	MODE 3 EV CABLE TESTING	40
6.3.1	<i>Manual electrical safety testing of Mode 3 EV cable</i>	40
6.3.1.1	Continuity measurement (R low 200 mA)	40
6.3.1.2	Insulation measurement (R iso)	41
6.3.1.3	Leakage current measurement	41
6.3.1.4	Testing resistance coding for vehicle coupling and plug	42
6.4	MONITORING WITH THE USE OF A 1631 EV MONITROING CABLE	43
6.4.1	<i>Monitoring of the charging process</i>	43
7	SAVING DATA AND REPORTING	45
8	ABBREVIATIONS	48
9	DOCUMENT VERSIONS	49
10	SOURCES	49

Table of figures

Figure 2.1:	The A 1632 eMobility Analyser	7
Figure 2.2:	Use case 1 – EVSE testing	8
Figure 2.3:	Use case 2 – Mode 2 EV cable testing	8
Figure 2.4:	Use case 4 – Mode 3 EV cable testing	9
Figure 2.5:	Use case 5 – Monitoring of charging process	9
Figure 3.1:	Type 1 connector and pin layout	11
Figure 3.2:	Type 2 connector and pin layout	12
Figure 3.3:	Type 3 socket and connector	13
Figure 3.4:	Type 1 CCS connector/inlet and pin layout	14
Figure 3.5:	Type 2 CCS connector/inlet and pin layout	15
Figure 3.6:	CHAdEMO inlet/connector and pin layout	16
Figure 3.7:	Charging case A	16
Figure 3.8:	Charging case B	16
Figure 3.9:	Charging case C	17
Figure 3.10:	Charging mode 1	17
Figure 3.11:	Charging mode 2	18
Figure 3.12:	Charging mode 3	18
Figure 3.13:	Charging mode 4	19
Figure 3.14:	Levels of charging states	20
Figure 3.15:	Charging speed	21
Figure 5.1:	Pairing the A 1632 eMobility Analyser with a master instrument	24
Figure 5.2:	Toggeling between operating modes (Mode 1 and Mode 2)	25

Figure 6.1: Starting the EVSED test with Master Instrument	26
Figure 6.2: 3-Basic EVSE configurations.....	27
Figure 6.3: Manual functional EVSE testing.....	28
Figure 6.4: Manual diagnostic testing.....	29
Figure 6.5: Semi-automated functional testing.....	30
Figure 6.6: Semi-automated diagnostic testing	31
Figure 6.7: Electrical safety testing	32
Figure 6.8: 1-Phase Mode 2 EV cable (left) and 3-Phase Mode 2 EV cable (right) configuration ..	33
Figure 6.9: Manual functional Mode 2 EV cable testing.....	34
Figure 6.10: Manual diagnostic Mode 2 EV cable testing on the input side	35
Figure 6.11: Manual continuity measurement procedure on a 1-phase Mode 2 EV cable.....	36
Figure 6.12: Manual insulation measurement procedure on a 1-phase Mode 2 EV cable	37
Figure 6.13: Manual IC-CPD measurement procedure on a 1-phase Mode 2 EV cable	38
Figure 6.14: Manual leakage measurement procedure on a 1-phase Mode 2 EV cable.....	39
Figure 6.15: 3-Basic Mode 3 EV cable configuration	40
Figure 6.16: Manual continuity measurement procedure on a 3-phase Mode 3 EV cable.....	41
Figure 6.17: Manual resistance coding measurement procedure on a 3-phase Mode 3 EV cable	42
Figure 6.18: 3-Basic monitoring configuration.....	43
Figure 6.19: CP communication monitoring during EV charging	44
Figure 7.1: Saving the results on the Master Instrument under the EVSE structure object.....	45
Figure 7.2: EVSE report example in MESM (part 1)	45
Figure 7.3: EVSE report example in MESM (part 2)	46
Figure 7.4: Starting MESM Help	46
Figure 7.5: MESM Help	47

Table of tables

Table 1: Type 1 CCS inlet/connector pins	13
Table 2: Type 2 CCS inlet/connector pins	14
Table 3: Maximum Mode 1 charging capabilities	17
Table 4: Maximum Mode 2 charging capabilities	18
Table 5: Maximum Mode 3 charging capabilities	19
Table 6: Maximum Mode 4 charging capabilities	19

1 Introduction

EVSE equipment testing is another sub-field of installation safety testing. As charging currents are high the charging equipment requires special attention in case of faults.

The EV charging equipment is constantly being put into use, which means it has to be regularly inspected and tested to maintain its functionality and reliability. Metrel has developed a special adapter to be able to do this, the A 1632 eMobility Analyser, which covers the international standard EN 61851-1 for testing EVSE equipment and EN 60364-7-722 for testing special installations or locations – supplies for electric vehicles.

This guide user guide covers an overview of the EN 61851-1 standard.

The test diagrams presented in this booklet are designed as a guideline for people involved in testing of EVSE equipment with A 1632 eMobility Analyser.

The guide itself cannot replace the standards EN 61851-1 and EN 60364-7-722 which have been used as a reference for preparation of this booklet.

For clarification on any part of this guide, contact Metrel d.d.

2 The A 1632 eMobility Analyser

The A 1632 eMobility Analyser is an adapter that can be used together with an installation tester, acting as a Master Instrument, to test Electrical Vehicle Supply Equipment (EVSE), Mode 2 and Mode 3 Electrical Vehicle (EV) charging cables and perform monitoring during charging.

The installation tester behaves as the Master Instrument and is capable of even controlling the A 1632 to some extent. The following Metrel instruments support the use of the A 1632 eMobility Analyser:

- MI 3155 EurotestXD
- MI 3152 EurotestXC
- MI 3152H EurotestXC 2,5 kV
- MI 3325 MultiServicerXD
- Android App (in development phase)



Figure 2.1: The A 1632 eMobility Analyser.

2.1 Contents of set

The A 1632 eMobility Analyser comes together with the following accessories:

- [A 1633](#): Mains supply cord 1 phase 10 A plug to 3 phase 16 A plug adapter
- [A 1634](#): Test cable with Type 2 male plug connector, length 2 m
- [A 1635](#): Test lead 2 mm / 4 mm safety banana plug adapter, red, length 1 m
- [A 1271](#): Bag for accessories
- Instruction manual
- Calibration certificate

2.2 Use cases

The A 1632 eMobility Analyser is intended to be used in the following use cases:

- **EVSE testing**
 - EVSE functional testing
 - EVSE diagnostic testing
 - EVSE electrical safety testing

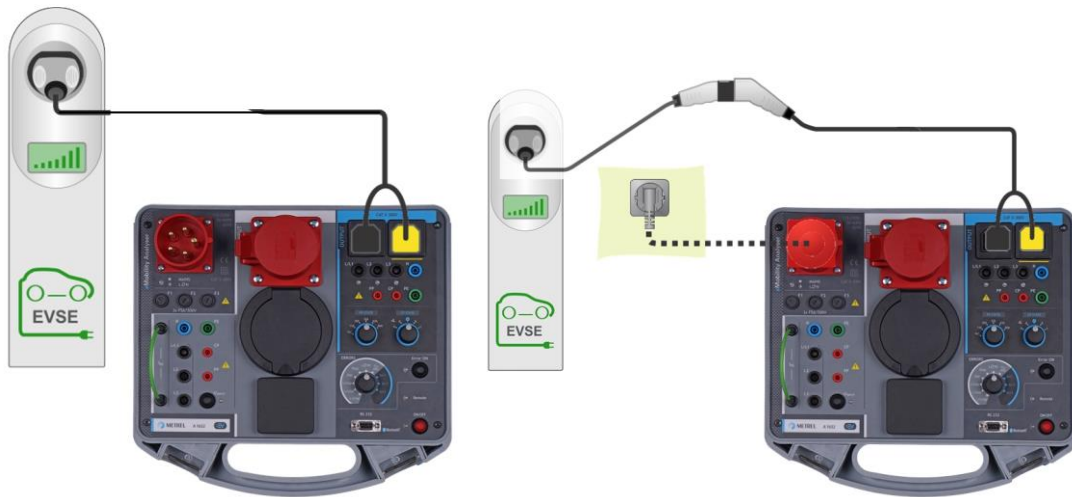

Figure 2.2: Use case 1 – EVSE testing

- **Mode 2 EV cable testing**
 - Mode 2 EV cable functional testing
 - Mode 2 EV cable diagnostic testing
 - Mode 2 EV cable electrical safety testing

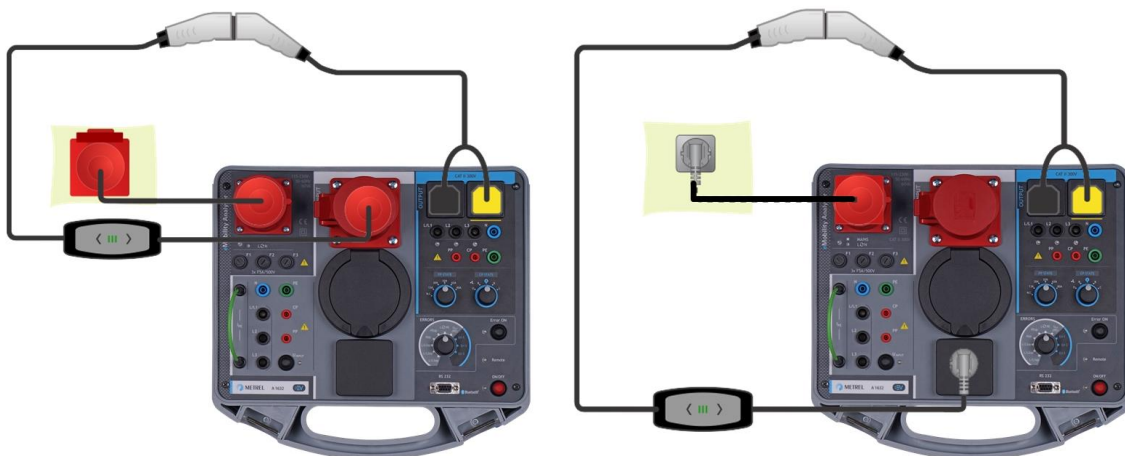

Figure 2.3: Use case 2 – Mode 2 EV cable testing

- **Mode 3 EV cable testing**
 - Mode 3 EV cable electrical safety testing on input and output side of A 1632

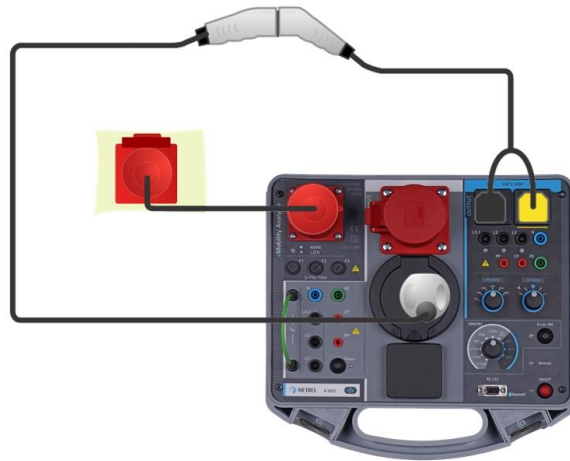

Figure 2.4: Use case 4 – Mode 3 EV cable testing

- **Monitoring of the charging process**

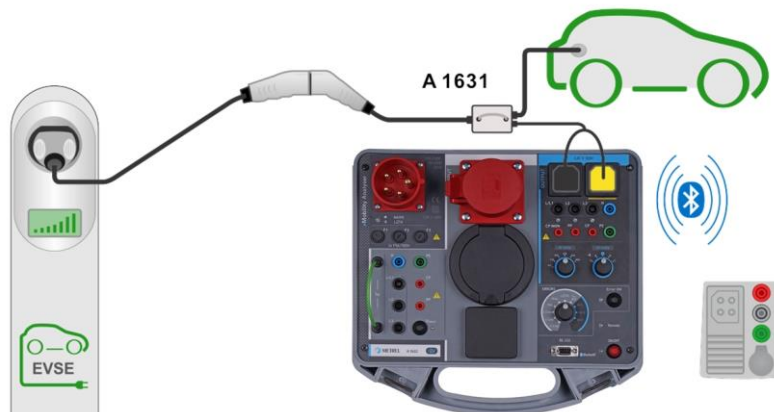



Figure 2.5: Use case 5 – Monitoring of charging process

2.3 EVSE testing

The eMobility Analyser is capable of presenting itself to the EVSE as an EV (part of the instrument that is marked with blue lining). To do this the A 1632 can simulate the following EV states:

- **A** → EV not connected to EVSE.
- **B** → EV connected, EVSE not charging.
- **C** → EV connected, EVSE charging.
- **D** → EV connected, EVSE charging, ventilation required by EVSE (e.g. during High Power Charging – HCP – or when the EV has lead batteries installed).

With the A 1632 it is possible to simulate the following errors on the EVSE equipment:

- Err1 / _{sh} → Diode short
- Err2 / **CP_{sh}** → CP-PE short (loss of communication between EVSE and EV).
- Err3 / **PE_{op}** → PE open

2.4 Mode 2 EV cable safety testing

The A 1632 is capable of testing Mode 2 and Mode 3 EV charging cables. When testing Mode 2 EV cables, it is possible to test them as an EVSE charging station or as an appliance. When tested as an EVSE charging station, the EV cable has to be connected to a 1-phase shucko inlet or a 3-phase CEE wall inlet. When tested as an appliance both parts of the cable have to be connected to the A 1632.

With the A 1632 we can simulate faults on the mains, i.e. the input side of the analyser. These faults allows us to verify the relevant safety features of the Mode 2 EV cable. The errors that can be simulated using only the A 1632 are:

- **L/L1_{op}** → L/L1 conductor opened
- **L/L2_{op}** → L/L2 conductor opened
- **L/L3_{op}** → L/L3 conductor opened
- **N_{op}** → N conductor opened
- **PE_{op}** → PE conductor opened
- **L_{PE}** → L/L1 and PE conductors crossed
- **U_{EXT} (PE)** → External voltage on PE (on input side)

Note: safety testing of Mode 2 EV charging cables is only possible when using the A 1632 eMobility Analyser. Support through Master Instruments is not possible.

Please refer to the A 1632 eMobility Analyser instruction manual for more details!

3 Standard EN 61851-1

3.1 EV connector types

3.1.1 Type 1

Facts:

- The Type 1 connector also referred to as the “Yazaki connector” by the Japanese manufacturer or the “J1772 connector” as it was published in SAE J1772.
- The connector supports only 1-phase AC charging up to 32 A.
- Mostly used in US and Japan and in some case also in Europe. The latest European Directive has now enforced the Type 2 and Type 2 CCS connectors.
- Type 2 and Type 1 connectors use the same CP and PP signalling, that is why one may use adapters in between.

The Type 1 connector has 5 pins:

- L/L1 conductor
- L2/N conductor
- PE conductor
- CP pin for communication during charging
- CS or PP pin for determining the maximum charging current allowed.

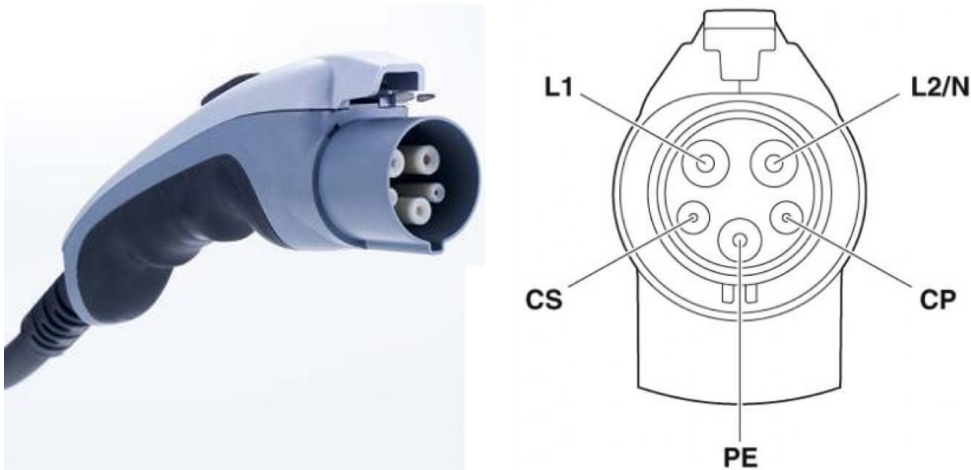

Figure 3.1: Type 1 connector and pin layout

Testing of AC charging stations with installed Type 1 connector is possible with the A 1632. An additional adapter between the Type 2 male connector and Type 1 socket is needed.

3.1.2 Type 2

Facts:

- Described in detail in IEC/EN 61851-1
- Know also as the Mennekes connector by the German manufacturer.
- Supports 1-phase AC charging up to 70 A or 3-phase AC charging up to 63 A.
- Used mostly within the European Union, since its regulation requires all public AC charging stations to be equipped with a Type 2 socket or a Type 2 connector.
- Type 2 and Type 1 connectors use the same CP and PP signalling, that is why one may use adapters in between.

The Type 2 connector has 7 pins:

- L1 conductor
- L2 conductor
- L3 conductor
- N conductor
- PE conductor
- CP pin for communication during charging
- PP pin for determining the maximum charging current allowed.



Figure 3.2: Type 2 connector and pin layout

Testing of AC charging stations and EV charging cable with either a Type 2 connector or socket is fully supported.

3.1.3 Type 3

Facts:

- Know also as Scame connector by the Italian manufacturer.
- Supports three different geometries; 1-phase AC charging at up to 16 A, without control pilot contact; 1-phase AC charging at up to 32 A and 3-phase AC charging at up to 63 A.
- Formerly used mostly in Italy and France. The latest EU regulation requires all public AC charging stations to be equipped with a Type 2 socket or a Type 2 connector. For this reason Type 3 connections are no longer used.



Figure 3.3: Type 3 socket and connector

Testing of AC charging stations with installed Type 3 is not supported with the A 1632.

3.1.4 Type 1 CCS

Facts:

- Type 1 CCS is a DC charging system.
- Type 1 CCS inlet on the EV allows both AC and DC charging via a Type 1 and Type 1 CCS connectors used respectively.
- Only male inlets exist for Type 1 (CCS) AC and DC charging. These may be installed only on the EV and never on the EVSE.
- CCS stands for Combined Charging Standard.

The Type 1 CCS inlet/connector has the following pins:

Conductor/pin	Inlet	Connector
L/L1	✓	
L2/N	✓	
PE	✓	✓
CP	✓	✓
PP	✓	✓
DC-	✓	✓
DC+	✓	✓

Table 1: Type 1 CCS inlet/connector pins



Figure 3.4: Type 1 CCS connector/inlet and pin layout

Even though the Type 1 and Type 1 CCS connectors use the same low-level communication (i.e. the CP pin), testing of DC charging stations with installed Type 1 CCS is not supported with the A 1632. The reason is that the CCS connection requires also high level communication which the A 1632 does not have.

3.1.5 Type 2 CCS

Facts:

- Type 2 CCS is a DC charging system.
- Type 2 CCS inlet on the EV allows both AC and DC charging via a Type 2 and Type 2 CCS connectors used respectively.
- Only male inlets exist for Type 2 CCS DC charging. These may be installed only on the EV and never on the EVSE.
- CCS stands for Combined Charging Standard.

The Type 2 CCS inlet/connector has the following pins:

Conductor/pin	Inlet	Connector
L1	✓	
L2	✓	
L3	✓	
N	✓	
PE	✓	✓
CP	✓	✓
PP	✓	✓
DC-	✓	✓
DC+	✓	✓

Table 2: Type 2 CCS inlet/connector pins

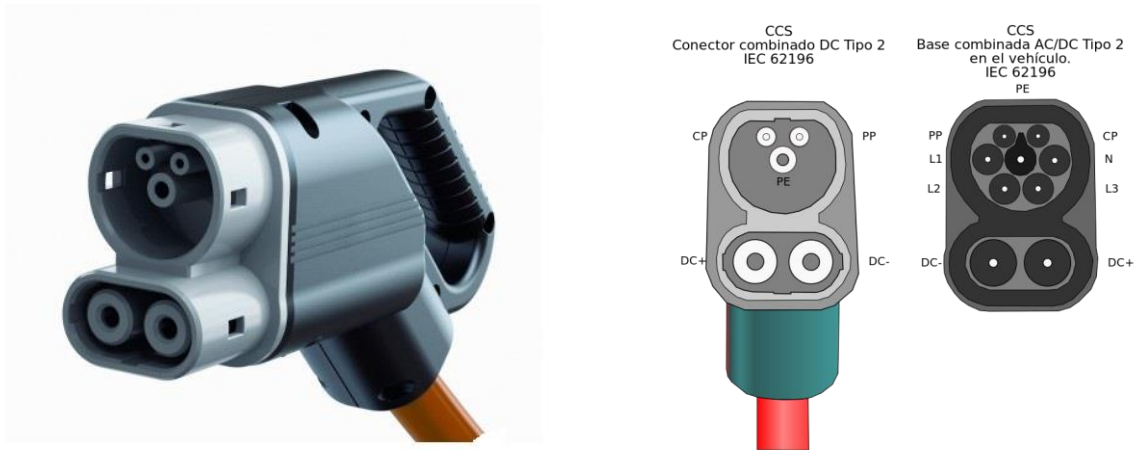

Figure 3.5: Type 2 CCS connector/inlet and pin layout

Even though that the Type 2 and Type 2 CCS connectors use the same low-level communication (i.e. the CP pin), testing of DC charging stations with installed Type 2 CCS is not supported with the A 1632. The reason is that the CCS connection requires also high level communication which the A 1632 does not have.

3.1.6 CHAdeMO

Facts:

- CHAdeMO is an abbreviation of “CHARge de MOve”, equivalent to “charge ‘n’ go”.
- Japanese standard.
- Not compatible with Type 1 or Type 2 low level communication.
- Used only for DC charging.
- Available also in most public charging stations in Europe.

The CHAdeMO inlet/connector has the following pins:

1. GND
2. Start/Stop charger
3. NC (not connected)
4. Start/Stop charging process
5. DC-
6. DC+
7. Control pilot (for connection control)
8. CAN bus High signal
9. CAN bus Low signal
10. Start/Stop charger.



Figure 3.6: CHAdeMO inlet/connector and pin layout

The CHAdeMO is a DC charging connector. The Japanese have also implemented their own high level communication protocol. Due to both reasons described, the DC charging stations with CHAdeMO connectors cannot be tested with the A 1632.

3.2 Charging cases explained

3.2.1 Charging Case A

Cable and vehicle connector are permanently attached to the EV. This case is actually not used.

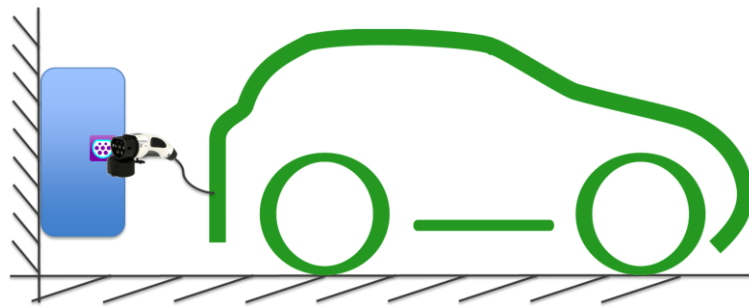

Figure 3.7: Charging case A

3.2.2 Charging Case B

Cable and vehicle connector detachable at both ends (EV and EVSE). Normally used in Mode 2 and Mode 3 charging, where the EVSE charging station is private or semi-private.

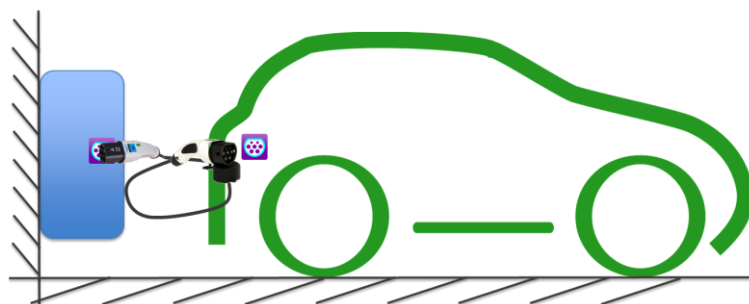

Figure 3.8: Charging case B

The A 1632 eMobility Analyser allows testing AC charging stations with Case B charging. To be able to test the EVSE's safety features, be sure to set the Proximity Pilot (PP) knob to the appropriate level in order to simulate the maximum allowed charging current.

3.2.3 Charging Case C

Cable and vehicle connector permanently attached to the EVSE. Used with public charging stations, especially in the case of fast charging or high power charging (HPC).

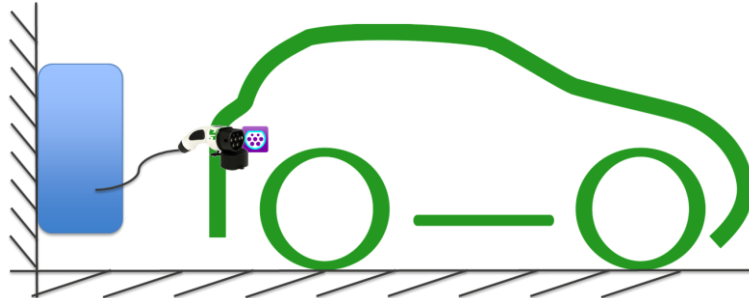

Figure 3.9: Charging case C

The A 1632 eMobility Analyser allows testing AC charging stations with Case C charging. To be able to test the EVSE's safety features, be sure to set the Proximity Pilot (PP) knob state N.C. (not connected).

3.3 Charging modes explained

3.3.1 Charging Mode 1

Charging mode 1 was intended for charging EVs at home using only a simple cable with 1- or 3-phase shuko/CEE plug on one side and a Type 2 or Type 1 female connector on the EV side.

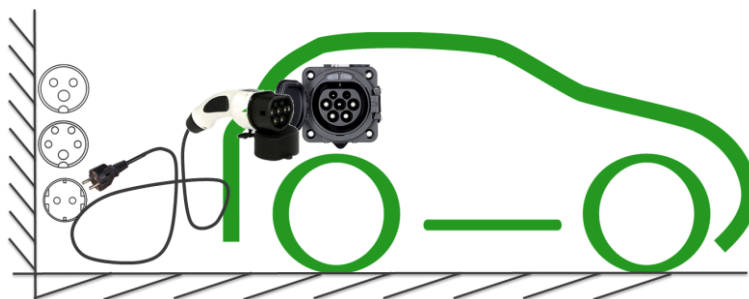

Figure 3.10: Charging mode 1

The maximum charging capabilities for Mode 1 charging can be seen from the table below:

Phase	Nominal current	Nominal voltage	Output power
1-phase	16 A	230 V a.c.	3,7 kW
3-phase	16 A	400 V a.c.	11,1 kW

Table 3: Maximum Mode 1 charging capabilities

Allowed connection cases for Mode 1 charging: **B**

Important: Since this cable does not offer any additional protection it has been banned from actual use.

3.3.2 Charging Mode 2

This charging mode is used for charging an EV anywhere (e.g. at home) using a 1-phase shuko or 3-phase CEE socket. It has an integrated IC-CPD device used for functional safety and an (P)RCD which provides electrical safety. The Mode 2 EV cable also has a heating sensor acting as an additional safety function which disconnects the charging if the temperature of the wall inlet exceeds maximum allowed temperature of the Mode 2 cable.

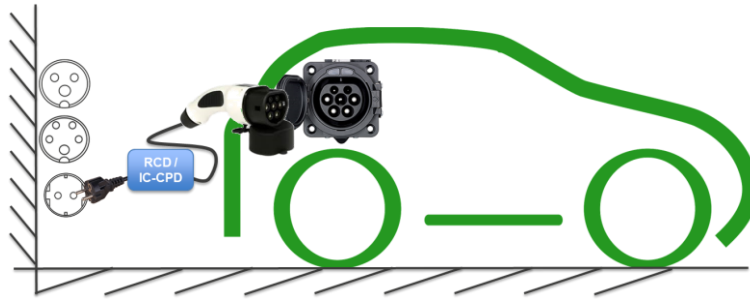

Figure 3.11: Charging mode 2

The maximum output power is 7.4 kW for 1-phase charging and 22.2 kW for 3-phase charging as seen from the table below:

Phase	Nominal current	Nominal voltage	Output power
1-phase	32 A	230 V a.c.	7,4 kW
3-phase	32 A	400 V a.c.	22,2 kW

Table 4: Maximum Mode 2 charging capabilities

Of course normal households would typically have less than 32 A of nominal current available, therefore the output power for a 1-phase connection would actually be approx. 3,7 kW.

Allowed connection cases for Mode 2 charging: **B**

Testing of Mode 2 EV charging cables is possible with the use of the A 1632 eMobility Analyser.

3.3.3 Charging Mode 3

This is the safest way of private, semi-private and public charging. These types of charging stations are AC type. The maximum power produced by such EVSE equipment is 7,3 kW when used with a 1-phase connection or up to 43,6 kW when used with a 3-phase connection. The most common charging power in public settings is 225,1 kW as the currents usually do not exceed 32 A.



Figure 3.12: Charging mode 3

The maximum charging capabilities for Mode 3 charging can be seen from the table below:

Phase	Nominal current	Nominal voltage	Output power
1-phase	63 A	230 V a.c.	14,5 kW
3-phase	63 A	400 V a.c.	43,7 kW

Table 5: Maximum Mode 3 charging capabilities

Allowed connection cases for Mode 3 charging: **B, C**

Testing of Mode 3 charging stations is possible with the use of the A 1632 eMobility Analyser.

3.3.4 Charging Mode 4

This mode is used for fast charging a.k.a high power charging. The typical output power is currently from 50 to 120 kW although EVSE equipment with up to 400 kW can already be seen on the market.



Figure 3.13: Charging mode 4

The maximum charging capabilities for Mode 4 charging can be seen from the table below:

Phase	Nominal current	Nominal voltage	Output power
DC	100 A	500V d.c.	50 kW
DC	125 A	400 V d.c.	50 kW
DC	350 A	500 V d.c.	175 kW
DC	500 A	900 V d.c.	450 kW

Table 6: Maximum Mode 4 charging capabilities

The charging speed is on the rise as manufacturers of DC charging equipment keep rising the charging current and voltage. Some manufacturers advertise their DC charging stations are capable of producing approx. 450 kW.

Allowed connection cases for Mode 4 charging: **C**

The A 1632 eMobility Analyser does not support testing of DC charging stations (e.i. Mode 4 charging).

3.4 Charging states

The Control Pilot (CP) is used when charging an EV with a Mode 2 EV cable or a Mode 3 EVSE. The pin is intended for communication between the EV and the charging unit. With it the EV introduces itself to the charging station and requests charging. The EVSE charging station is the master in this case since it decides whether or not the EV connected can be charged.

According to the EN 61851-1 standard, the following CP states are defined:

- A → EV not connected to EVSE.
- B → EV connected, EVSE not charging.
- C → EV connected, EVSE charging.
- D → EV connected, EVSE charging, ventilation required by EVSE.
- E → Error.

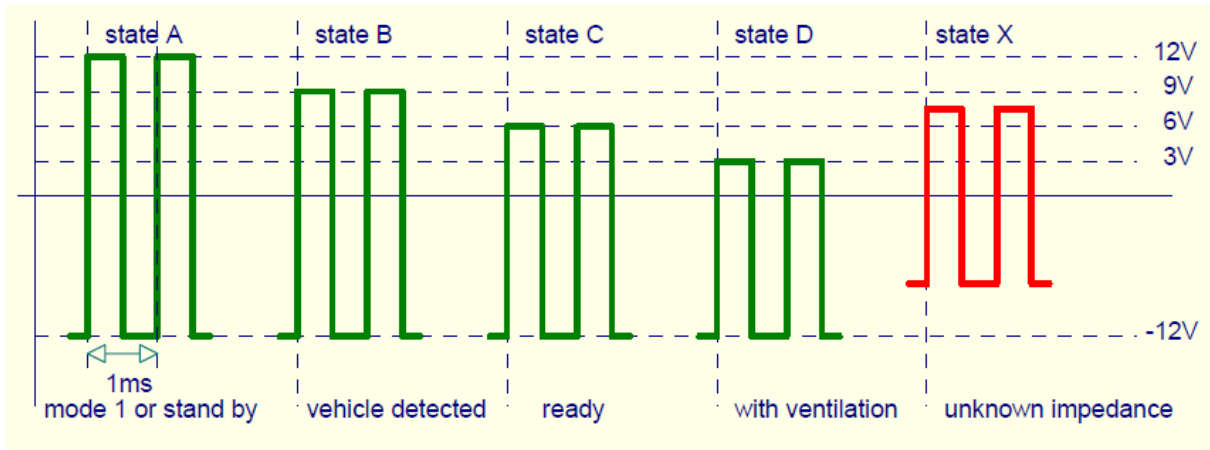

Figure 3.14: Levels of charging states

The EVSE sets the duty cycle of the PWM control pilot (CP) signal to indicate the maximum current that the EV may draw from the EVSE. The EV must then apply a resistive load accordingly as not to request more current than the charging station is willing to provide. Typically this will be seen as a transition from state x1 to x2, where x can be any of the known states (A, B, C or D). State x1 indicates the unavailability whereas state x2 indicates the availability of power supply to the EV.

3.5 Max. charging current (i.e. charging speed)

Charging speed is determined through the Proximity Pilot (PP). The PP is a resistor connected between the PP pin and the PE pin on the Type 2 connector or socket of a Mode 2 EV cable, a Mode 3 EVSE charging station or the EV. The coding of the resistor actually determines what cable is being used (the cross section) which further determines the maximum charging current and consequently charging speed. The PP resistor can have the following values according to EN 61851-1:

- 1500 Ω → 13 A Charging cable
- 680 Ω → 20 A Charging cable
- 220 Ω → 32 A Charging cable
- 100 Ω → 63 A Charging cable

Cables used for DC charging usually offer higher charging currents from 100 A to 400 A or even 500 A. All cables that use a charging current of more than 200 A must have some sort of cooling installed inside the cable (water or transformer oil).

Additionally the charging speed is determined by the EVSE through the duty cycle of the Pulse Width Modulation (PWM) signal. The higher the duty cycle the faster the charging as can be

seen from Figure 3.15. The EV must follow the maximum allowed current limit set by the EVSE, otherwise the charging station may stop the charging process.

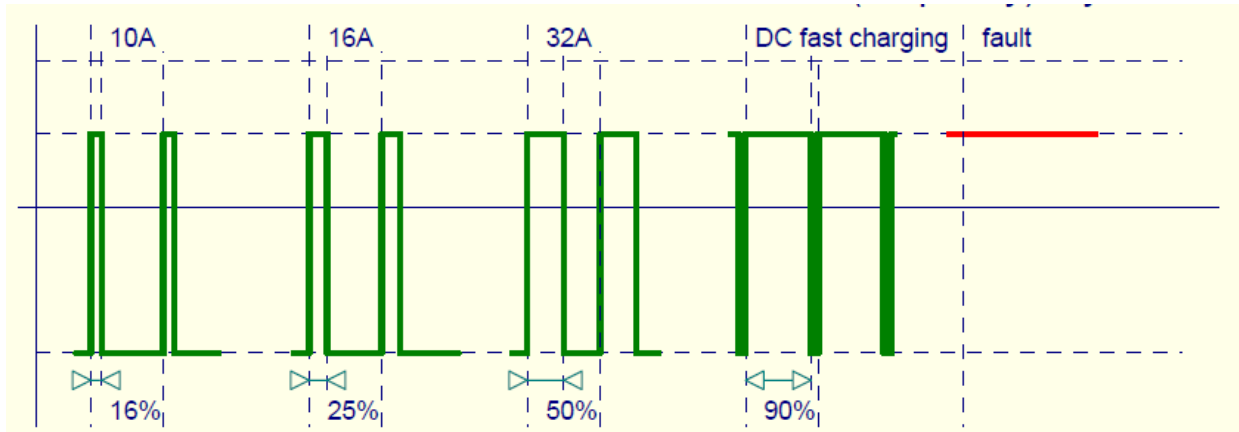

Figure 3.15: Charging speed

If the measured value if the ducty cycle is between 10 % and 85 %, then the maximum current can be measured according to the following equation:

$$I_{\max} = \text{Duty_cycle} \times 0,6 \text{ A}$$

If the measured value if the duty cycle is between 85 % and 96%, then the maximum current can be measured according to the following equation:

$$I_{\max} = (\text{Duty_cycle} - 64) \times 2,5 \text{ A}$$

Duty cycle higher than 96% is considered an error.

4 Recommended inspections and inspection intervals

This chapter refers to the eCheck directive (Richtlinie zum E-CHECK E-Mobilität, © 2017 ArGe Medien im ZVEH) and has been modified to meet the Metrel defined solution.

4.1 Inspection of EVSE

- Visual inspection of EVSE
- Periodic inspections of electrical installation in operation according to EN 60364-6 and EN 61851:

Task	Measuring method	Values	Remark
Continuity of wires	R low	$PE < 1,0 \Omega$	State B
R ISO (Lx-PE; N-PE)	R ISO	$\geq 1,0 M\Omega$	State B
RCD test	RCD I, RCD t for RCD types AC, EV, B	$I_{\Delta N} \leq 30 \text{ mA a.c.};$ 6 mA d.c.	State C
Impedance meas.	Z line, Zloop	$Z_s \leq (2 \cdot U_o) / (I_a)$	State C
PE leakage current	I (Current)	$I_{meas} \leq 0,4 \times I_{\Delta N}$	Optional
Current on N wire	I (Current)	$I_{meas} \leq I_L$	Optional

- Periodic functional inspections of EVSE according to EN 61851 (CP states A, B, C/D, E)

4.2 Inspection of Mode 2 EV cable

- Visual inspection of Mode 2 EV cable.
- Periodic inspections:

Task	Method	Values	Remark
Continuity of wires	R low	$< 0,3 \Omega (5\text{m}) + 0,1 \Omega/\text{m} (1 \Omega \text{ max.})$	State C
R ISO (Lx-PE; N-PE)	R ISO	$\geq 1,0 M\Omega$ (secondary side)	State B
(P)RCD test	RCD I, RCD t for PRCD	$I_{\Delta Na} < I_{\Delta N}$	State C
Impedance meas.	Z line, Zloop	$Z_s \leq (2 \cdot U_o) / (I_a)$	State C
PE leakage current	I (Current)	$\leq 3.5 \text{ mA}$	State C

- Periodic functional inspections of EVSE according to EN 61851 (CP states)
- Periodic functional inspection of Mode 2 cable

Testing object	Features	Values
ICCB charging current on Mode 2 EV cable	6 A	Yes / No
	8 A	Yes / No
	10 A	Yes / No
	13 A	Yes / No
	16 A	Yes / No
Function test by means of an adapter (A 1632)	Function test – shutdown	Yes / No
	Interruption L	Yes / No
	Interruption N	Yes / No

	Interruption PE Interchange L-PE External voltage U external to PE	Yes / No Yes / No Yes / No
Vehicle status	Functional test	Values
Check status A	EV not connected, EVSE not charging	Yes / No
Check status B	EV connected, EVSE not charging	Yes / No
Check status C	EV connected, EVSE charging (no ventilation required)	Yes / No
Check status D	EV connected, EVSE charging (ventilation required)	Yes / No
Check status E1	CP diode shorted	Yes / No
Check status E2	CP – PE shorted	Yes / No
Check status E3	PE opened	Yes / No

4.3 Inspection of Mode 3 EV cable

- Visual inspection of Mode 2 EV cable.
- Periodic inspections:

Task	Method	Values
Continuity of wires	R low	< 0,3 Ω (5m) + 0,1 Ω /m (1 Ω max.)
R ISO (Lx-PE; N-PE)	R ISO	\geq 1,0 M Ω (secondary side)
PE leakage current	I (Current)	\leq 3.5 mA
Testing resistance coding for vehicle coupling and plug	Testing resistance coding	13 A Charging cable 1500 Ω 20 A Charging cable 680 Ω 32 A Charging cable 220 Ω 63 A Charging cable 100 Ω 80 A Charging cable 56 Ω

4.4 Inspection intervals

When	Where	What	Who
Daily	Charging station	Visual inspection before use	User
		Control of operational readiness	Operator
Every ½ year	RCD	Operation of test button	Operator
	Mode 2 & mode 3 charging cable	Periodical testing according to VDE 0701/702, EN 61439	Authorized person
Yearly	Whole system	Periodical testing according to EN 60364-6, EN 60364-7-717, EN 60364-7-722, VDE 0105 -100	Authorized person
	Charging station	Traffic safety inspections	Operator

5 Settings on the A 1632 and Master Instrument

5.1 Pairing the A 1632 eMobility Analyser with the Master Instrument

Before performing remote diagnostic tests of an EVSE with the A 1632 eMobility Analyser being used as an remote adapter, a Master Instrument (e.g. MI 3155) and the A 1632 have to be paired.

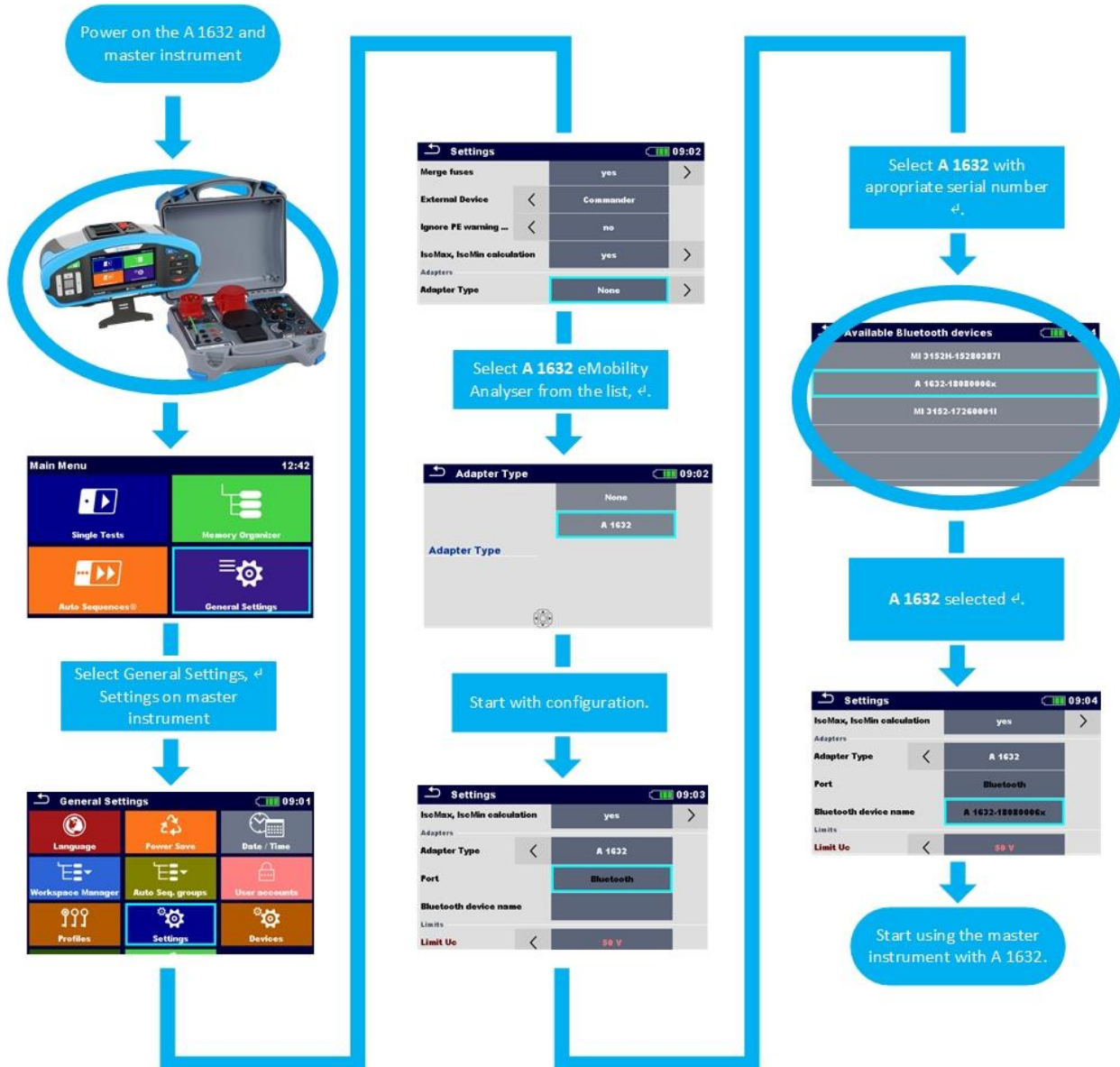

Figure 5.1: Pairing the A 1632 eMobility Analyser with a master instrument

5.2 Setting the A 1632 eMobility Analyser operating modes

The A 1632 may be used in one of the two operating modes:

- **Mode 1** (default) – Suitable for TN and TT voltage systems where N conductor is present. The PE INPUT connector is connected to the installation's N conductor. No RCD tripping.
- **Mode 2** – Suitable for any voltage system, including IT. The PE INPUT connector is connected to the installation's PE conductor.

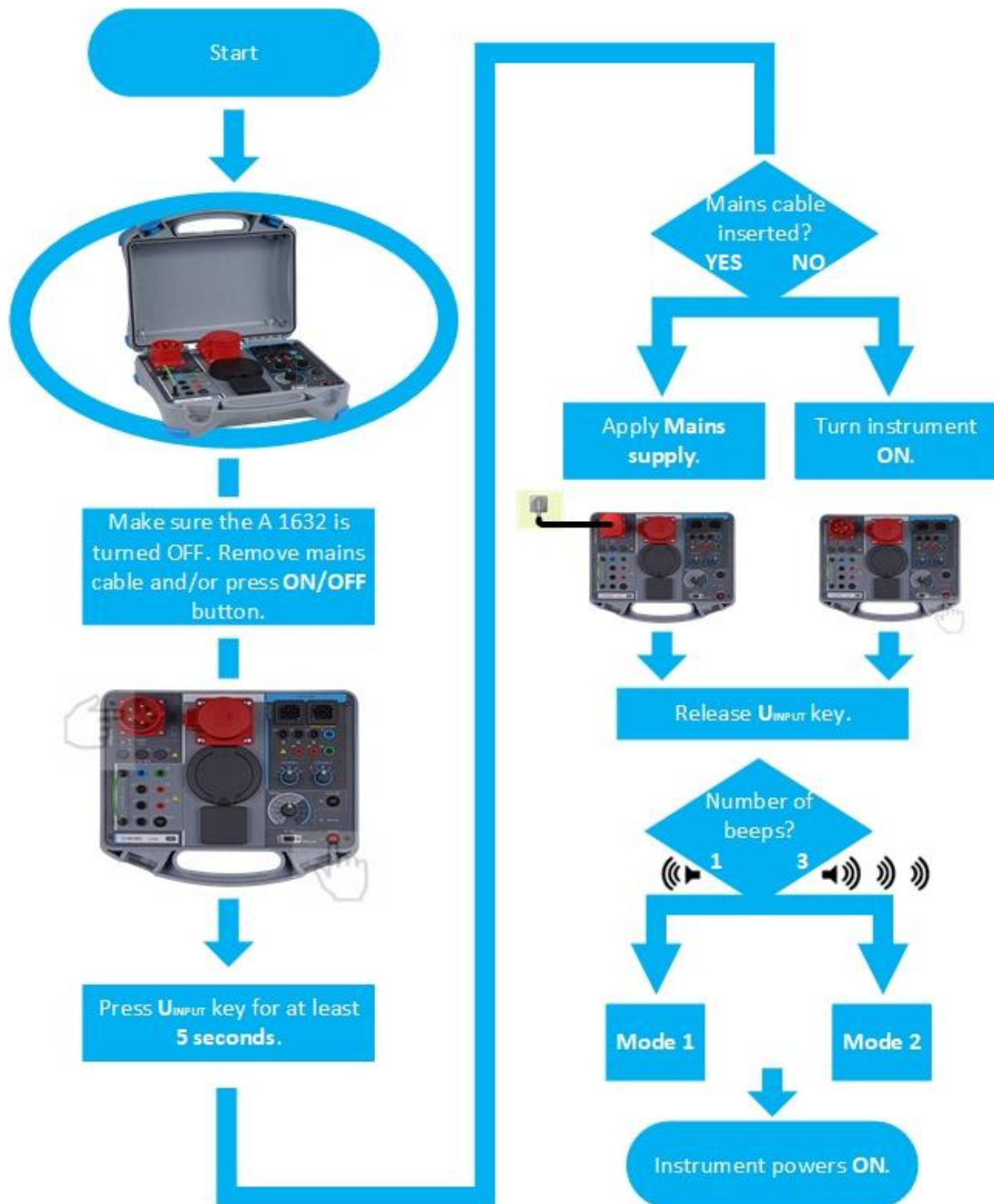

Figure 5.2: Toggling between operating modes (Mode 1 and Mode 2)

6 Performing measurements

After pairing of the Master Instrument with the A 1632 eMobility Analyser has been done, it is possible to perform diagnostic testing with the Master Instrument being in control. To begin testing, power ON the Master Instrument and follow the procedure:

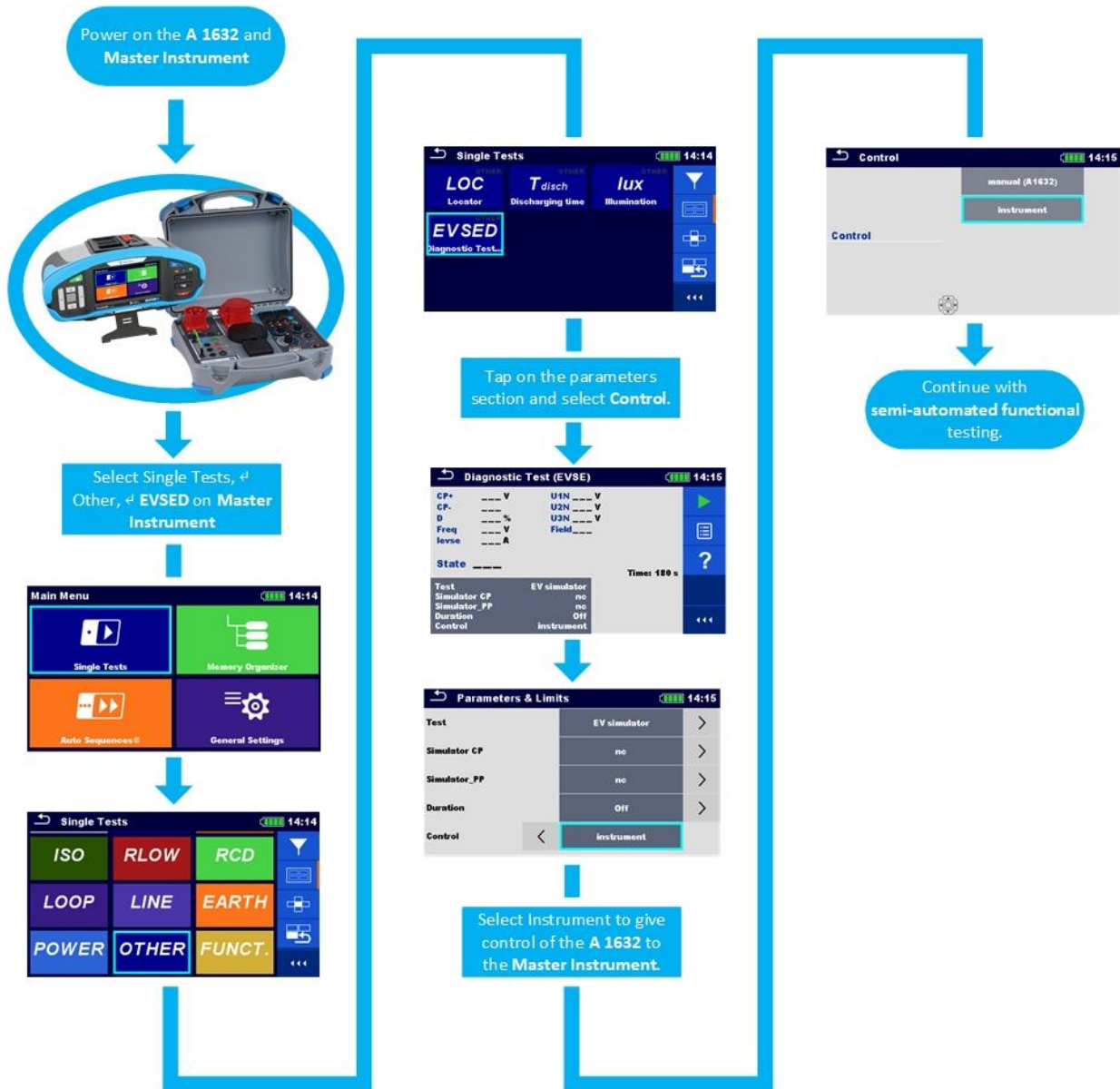

Figure 6.1: Starting the EVSED test with Master Instrument

6.1 EVSE charging station testing

Basic EVSE testing information for further information regarding CP and PP states.

Functional, error and electrical safety testing can be performed manually both on Electrical Vehicle Charging stations (EVSE) as well as on Mode 2 EV charging cables when operated as a EVSE.



Figure 6.2: 3-Basic EVSE configurations

6.1.1 Manual functional and diagnostic EVSE testing

If the intention is only to test whether or not the EVSE reacts accordingly to the initiated electrical vehicle (EV) states and error situations, then the manual functional testing is sufficient. In this case the procedures described below in Figure 6.3 and Figure 6.4 should be performed.

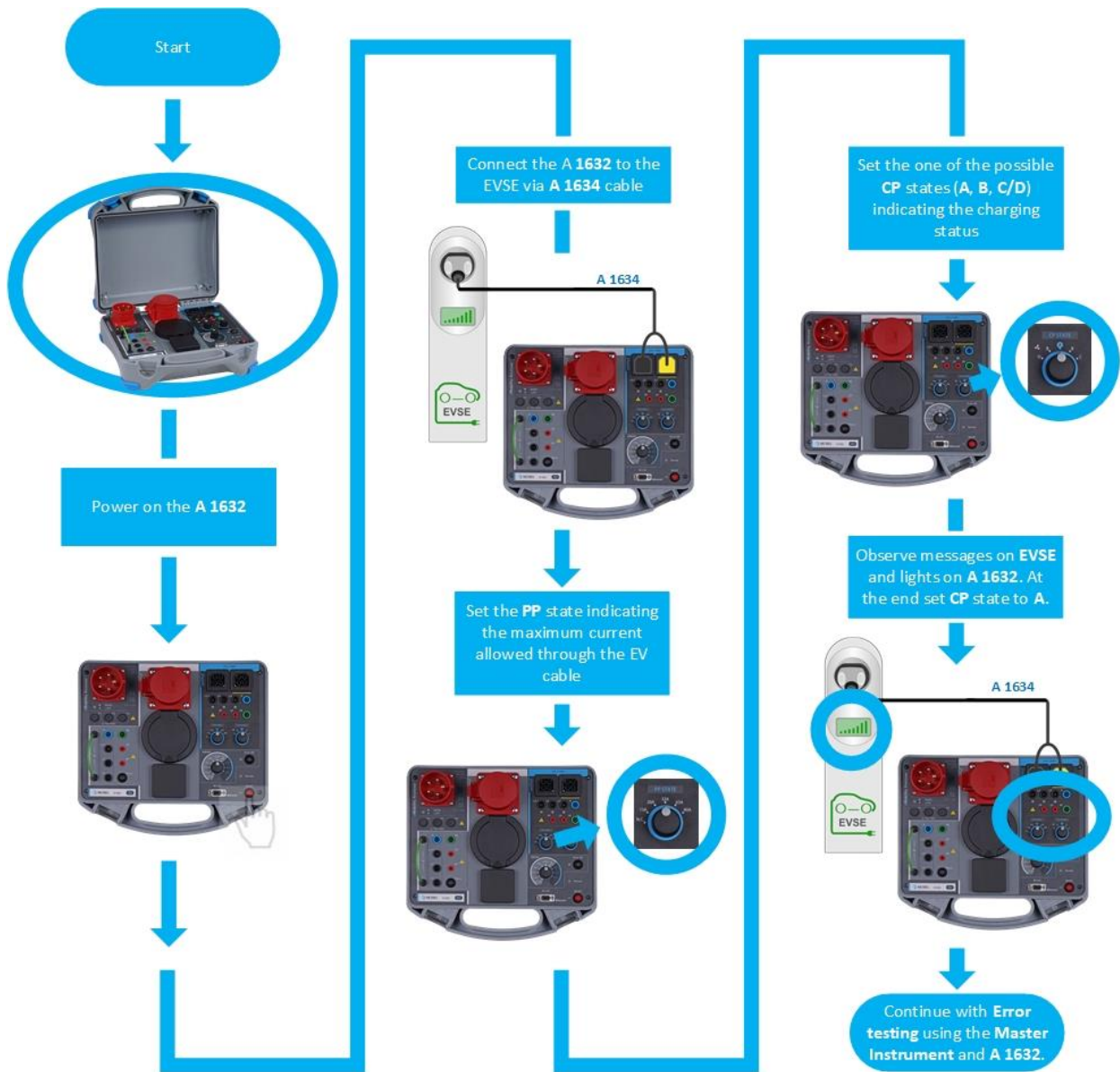

Figure 6.3: Manual functional EVSE testing

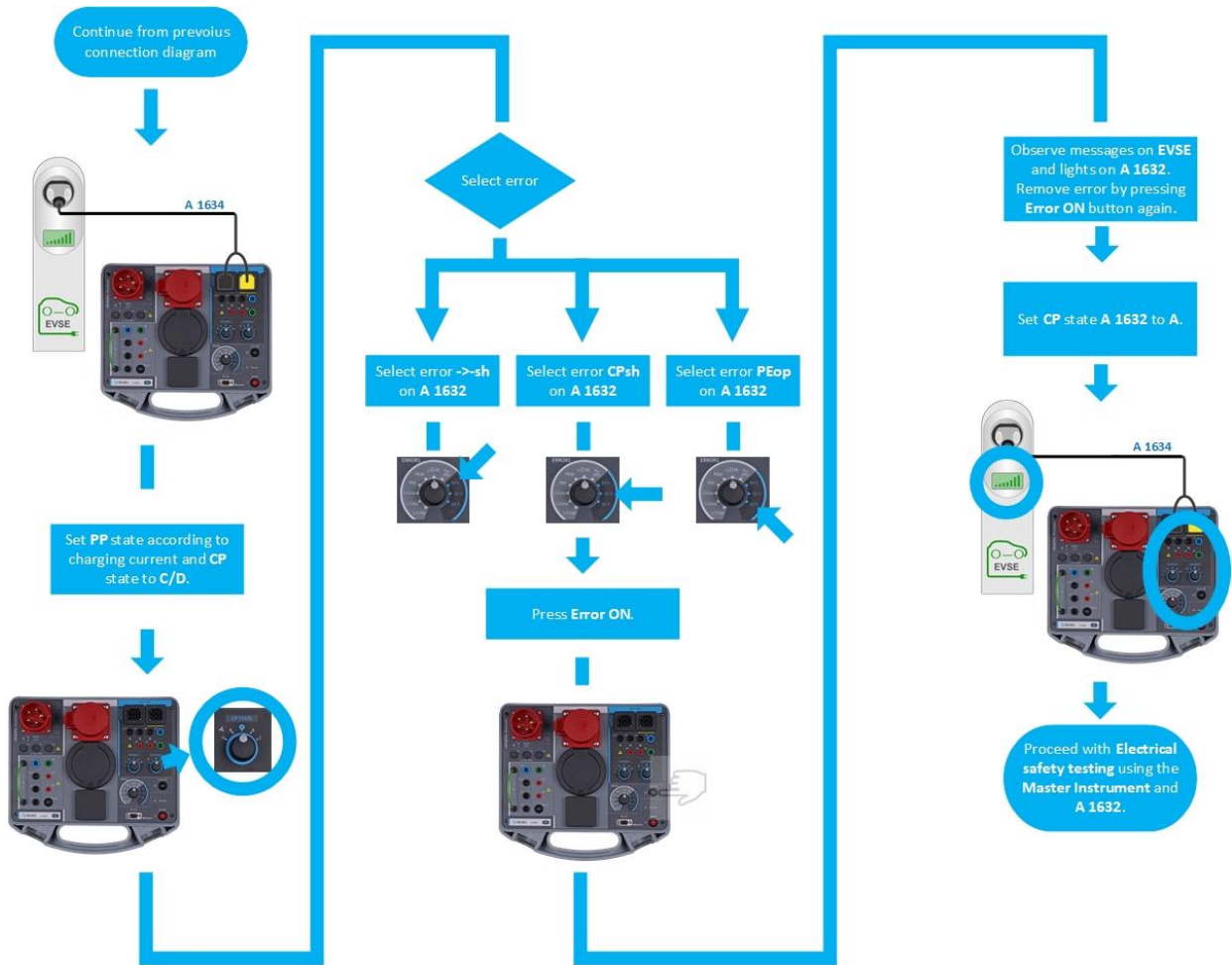

Figure 6.4: Manual diagnostic testing

6.1.2 Semi-automated functional and diagnostic EVSE testing

If the purpose is to test whether or not the EVSE reacts accordingly to initiated electrical vehicle (EV) states, error situations and save the results, then the use of semi-automated functional and diagnostic testing procedures is the way to go. In this case follow the procedures described in Figure 6.5 and Figure 6.6.

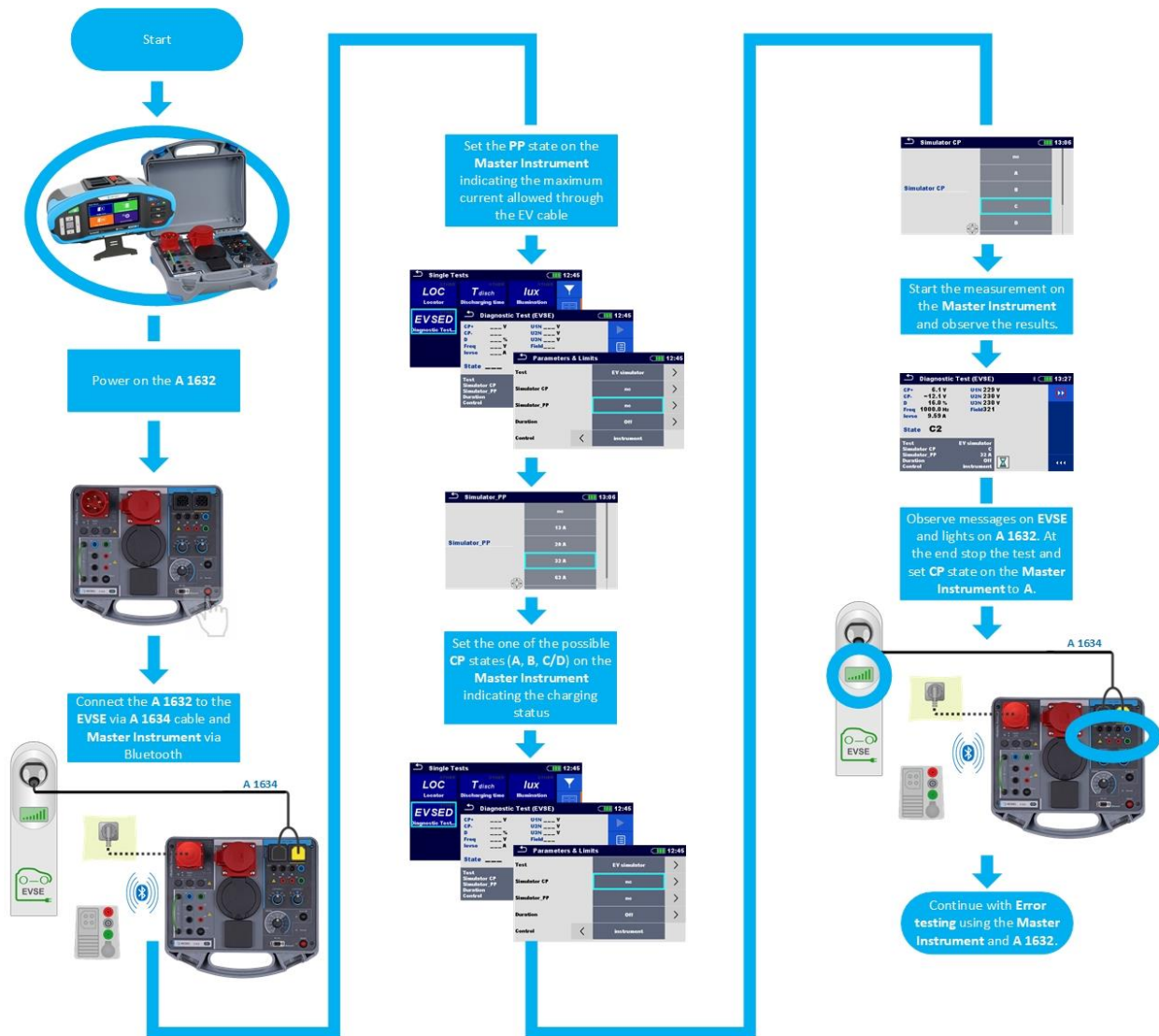

Figure 6.5: Semi-automated functional testing

Figure 6.6 shows how to select an error on the Master Instrument. After selecting an error (e.g. C → Err1) and upon pressing the start button on the Master Instrument, the remote light on the A 1632 will be turned on and the A 1632 will drive the Mode 2 cable or the EVSE to state C. The Master Instrument will wait additional 5 seconds before initiating an error on the output side of the A 1632 to make sure that the EVSE charging station reached state C. After the time will expire, the error will occur on the output side causing the EVSE to disconnect the power. The Master Instrument will record the last states of the CP+, CP-, duty cycle... and measure the disconnection time (toff). The user then has the capability to choose between PASS and FAIL of the test. Once confirmed the test is stopped and the possibility to save the results is presented.

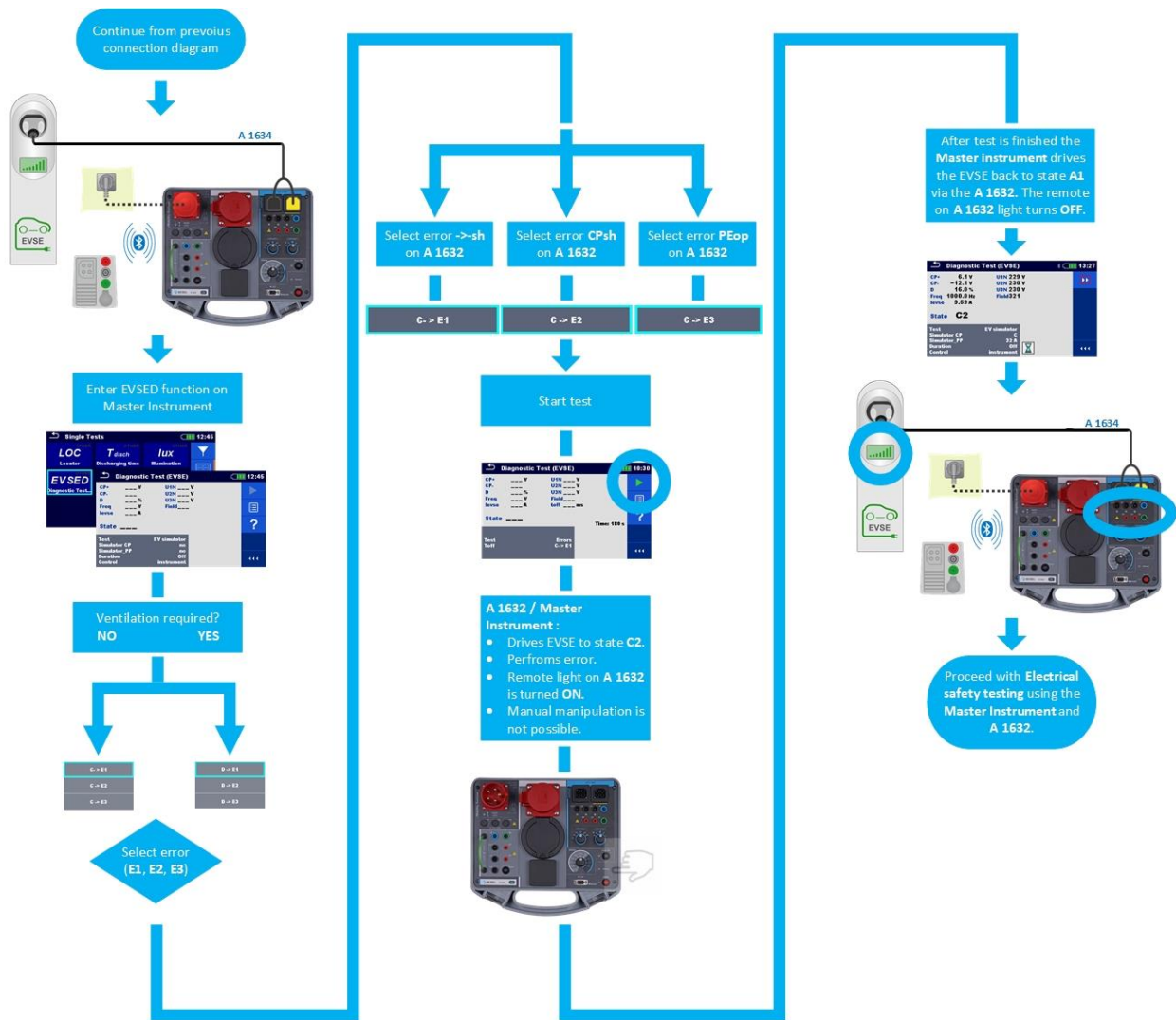

Figure 6.6: Semi-automated diagnostic testing

6.1.3 Automated electrical safety EVSE testing

After diagnostic testing (functional end error) of the EVSE has been done, simply start an Auto Sequence according to the way the EVSE has been installed and follow the procedure explained in the selected Auto Sequence. After the Auto Sequence has finished, save the results. The EVSE has now been completely tested, functionally and electrically. An example of a user selected Auto Sequence can be seen in Figure 6.7.

Typical tests done at each CP state:

- CP state B
 - R iso test between Lx and PE.
 - R iso test between N and PE.
- CP state C/D
 - U test between Lx, N & PE.
 - Z auto test on all Lx → $Z_{\text{auto}} = Z_{\text{Line}} + Z_{\text{Loop}} + UC + \Delta U$
 - EV RCD Auto test (if RCD is available).

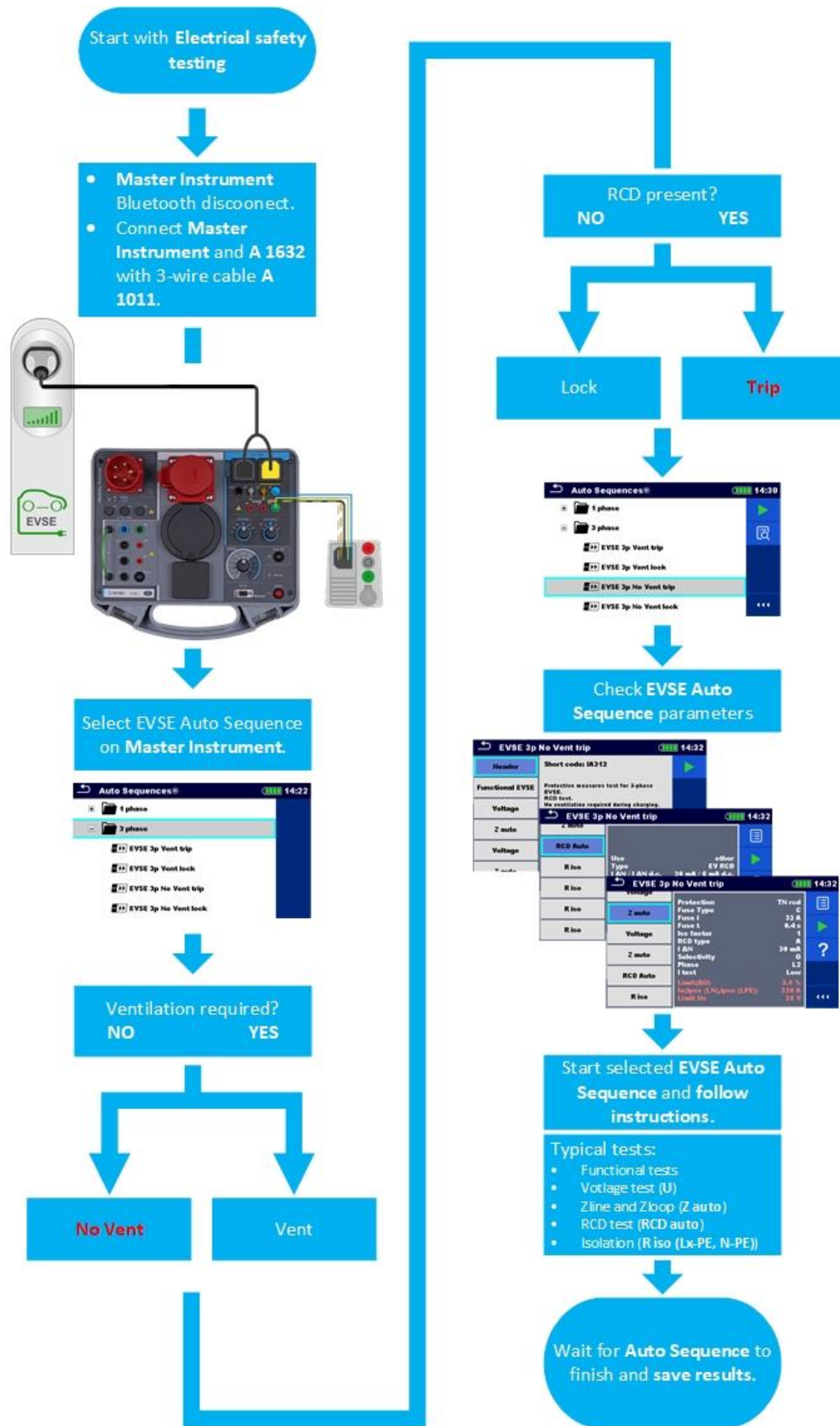

Figure 6.7: Electrical safety testing

6.2 Mode 2 EV cable testing

It is also possible to test a Mode 2 EV cable in the same way as an EVSE station. In such case simply repeat the procedures described in chapters 6.1.1 or 6.1.2 in combination with 6.1.3. Use the following configurations instead:

When testing Mode 2 EV cables with the A 1632 eMobility Analyser the functional tests on the output side may be done either manually on the A 1632 or remotely using a Master Instrument. In such case the Mode 2 EV cable actually behaves similarly to the EVSE charging station. To test the Mode 2 EV cable as an EVSE simply repeat the procedures described in chapters 6.1.1 or 6.1.2 in combination with 6.1.3 with one of the configurations shown in Figure 6.8.

When we wish to test Mode 2 EV cables as appliances, then first the diagnostic/error tests have to be made on the input side. These can only be made manually using the A 1632 eMobility Analyser. Semi-automatic and automatic procedures are not possible via a Master Instrument as the errors are not supported in Master Instrument's FW.

At the end, electrical tests have to be made. These tests may be done either manually (as explained in this quick guide) or fully automated, providing that the reader has prepared an Auto Sequence to accommodate such testing.

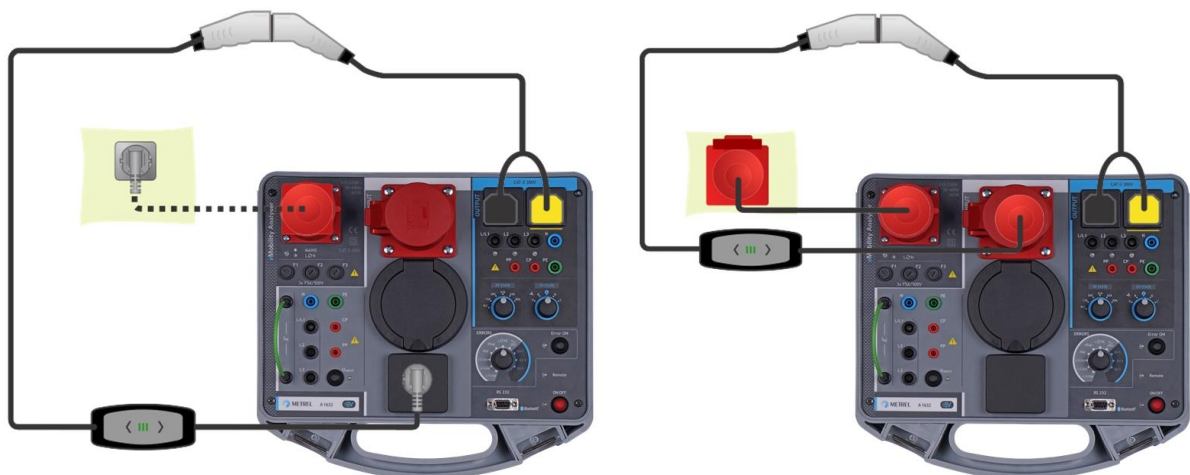

Figure 6.8: 1-Phase Mode 2 EV cable (left) and 3-Phase Mode 2 EV cable (right) configuration

6.2.1 Manual functional Mode 2 EV cable testing

To test the complete functionality of a Mode 2 EV cable follow the procedure described below.

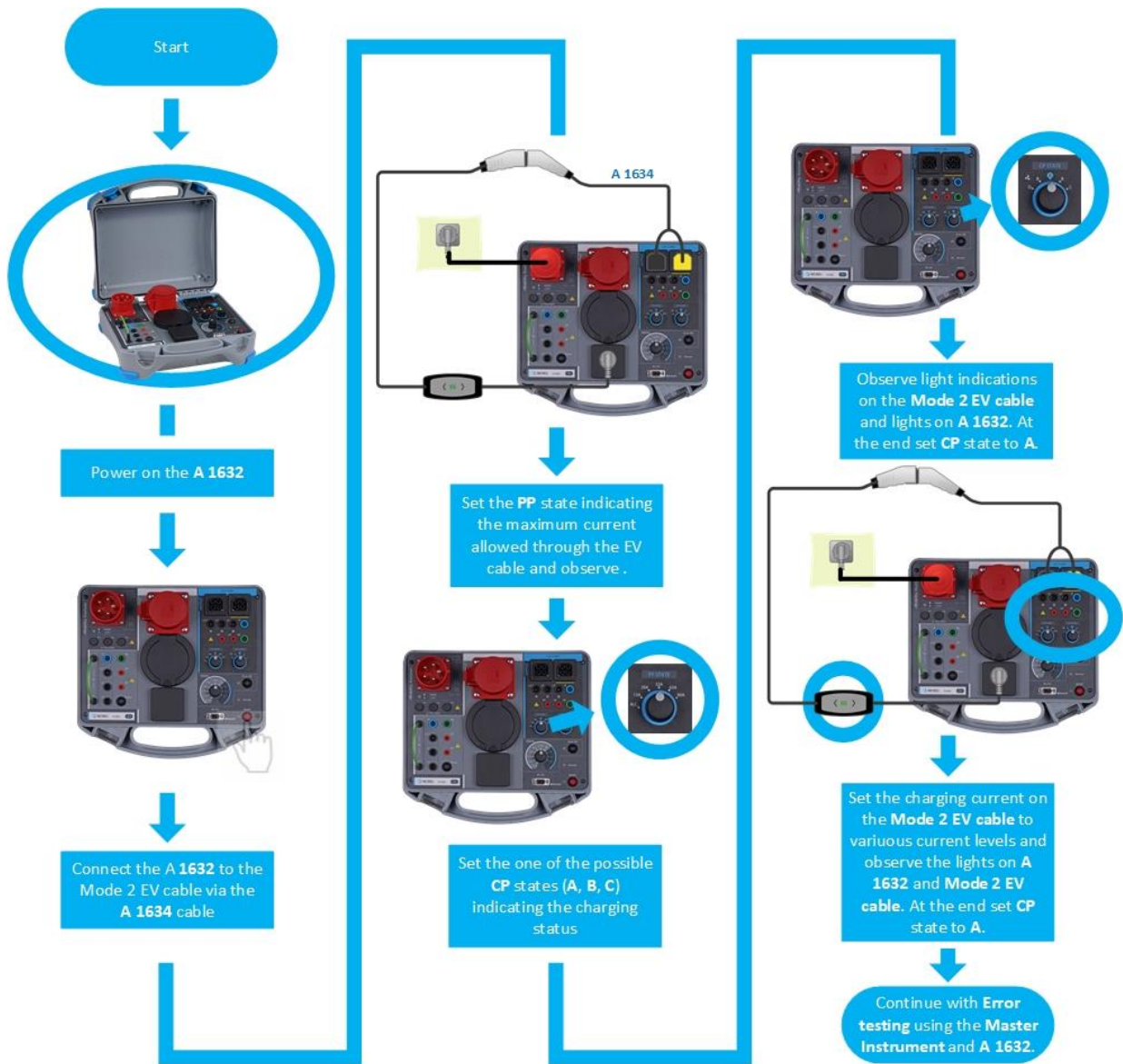

Figure 6.9: Manual functional Mode 2 EV cable testing

6.2.2 Manual diagnostic Mode 2 EV cable testing on the input side

To see how the Mode 2 EV cable responds to various error conditions on the input side of cable follow the procedures shown below in Figure 6.10.

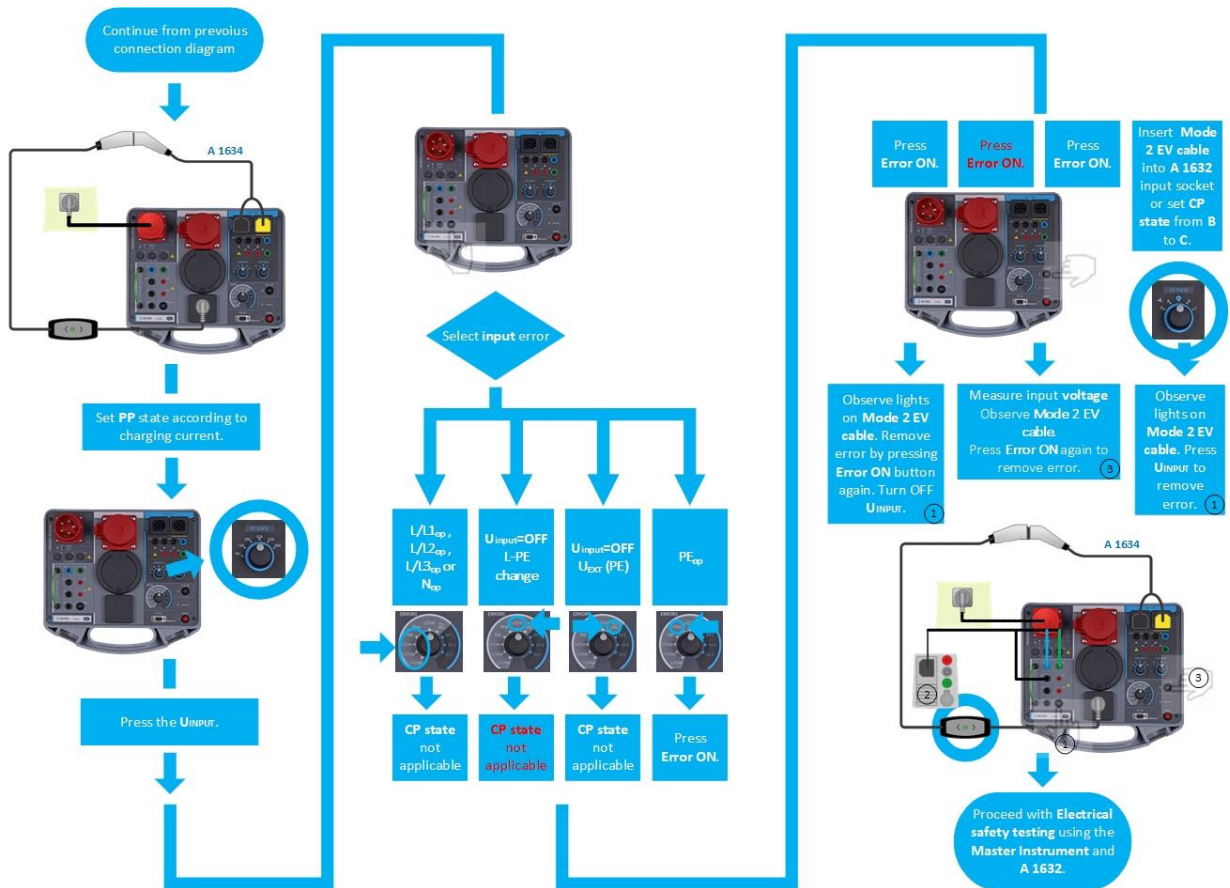

Figure 6.10: Manual diagnostic Mode 2 EV cable testing on the input side

6.2.3 Manual diagnostic Mode 2 EV cable testing on the output side

For diagnostic testing of Mode 2 EV charging cables on the output side use one of the connection diagrams shown in Figure 6.8. Refer to chapters 6.1.1 or 6.1.2 for the proposed procedures with Mode 2 EV cable in mind.

6.2.4 Semi-automated functional and diagnostic Mode 2 EV cable testing on the output side

Please refer to chapter 6.1.2 for the complete semi-automated procedures on functional and diagnostic Mode 2 EV cable testing. Replace the connection to the ones shown in diagrams in Figure 6.8.

6.2.5 Manual electrical safety testing of Mode 2 EV cable

6.2.5.1 Continuity measurement (R low 200 mA)

The measurement is done with the Master Instrument on each conductor between the input and the output terminal.

To be able to measure the continuity of a Mode 2 EV cable the cable itself has to have all ports opened. This is achieved with putting the A 1632 eMobility Analyser into CP state C. In order not to trip the IC-CPD (a variety of the PRCD-S+) the Master Instrument has to have the parameter **Current** set to **ramp**.

When the continuity test is done on all conductors, regardless whether it is a 1-phase or a 3-phase Mode 2 EV cable, the polarity is also proven or rejected. The procedure described in Figure 6.11 shows how to test the continuity on a 1-phase Mode 2 EV cable.

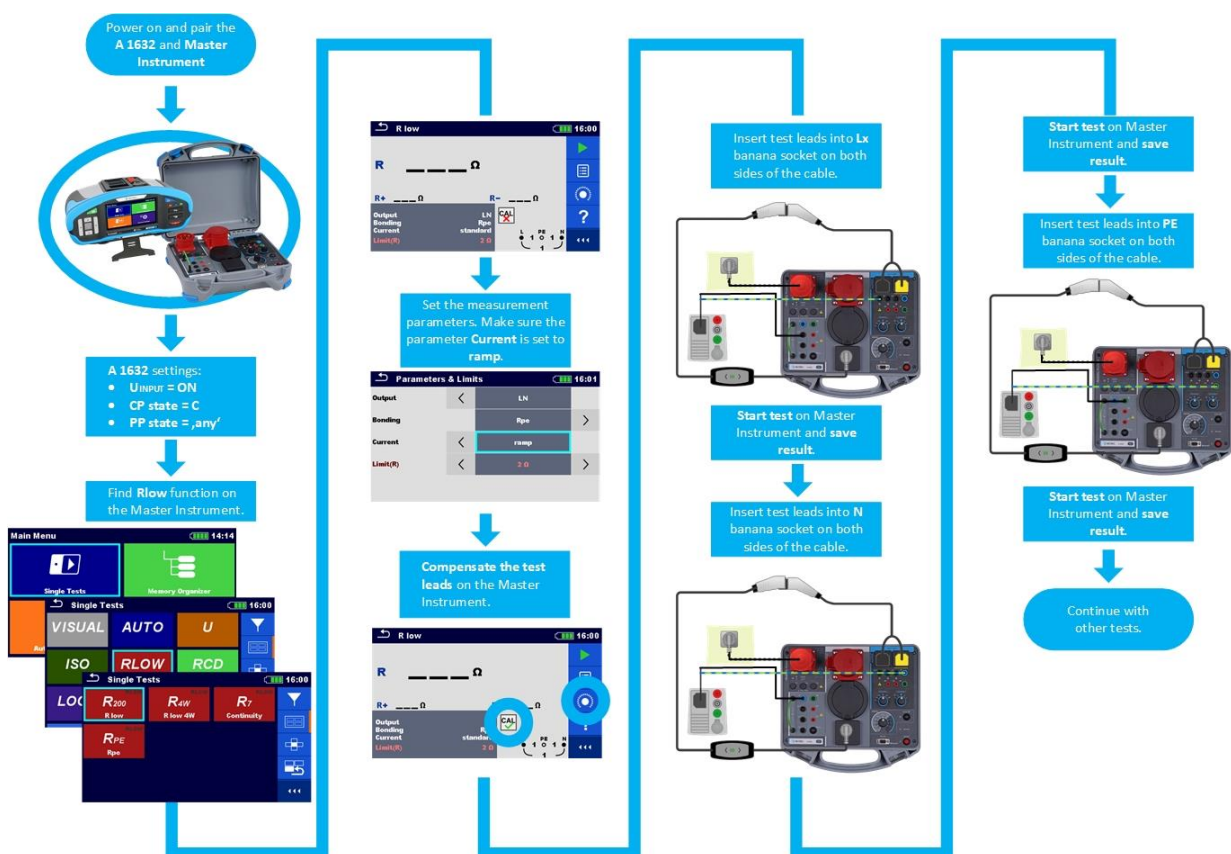
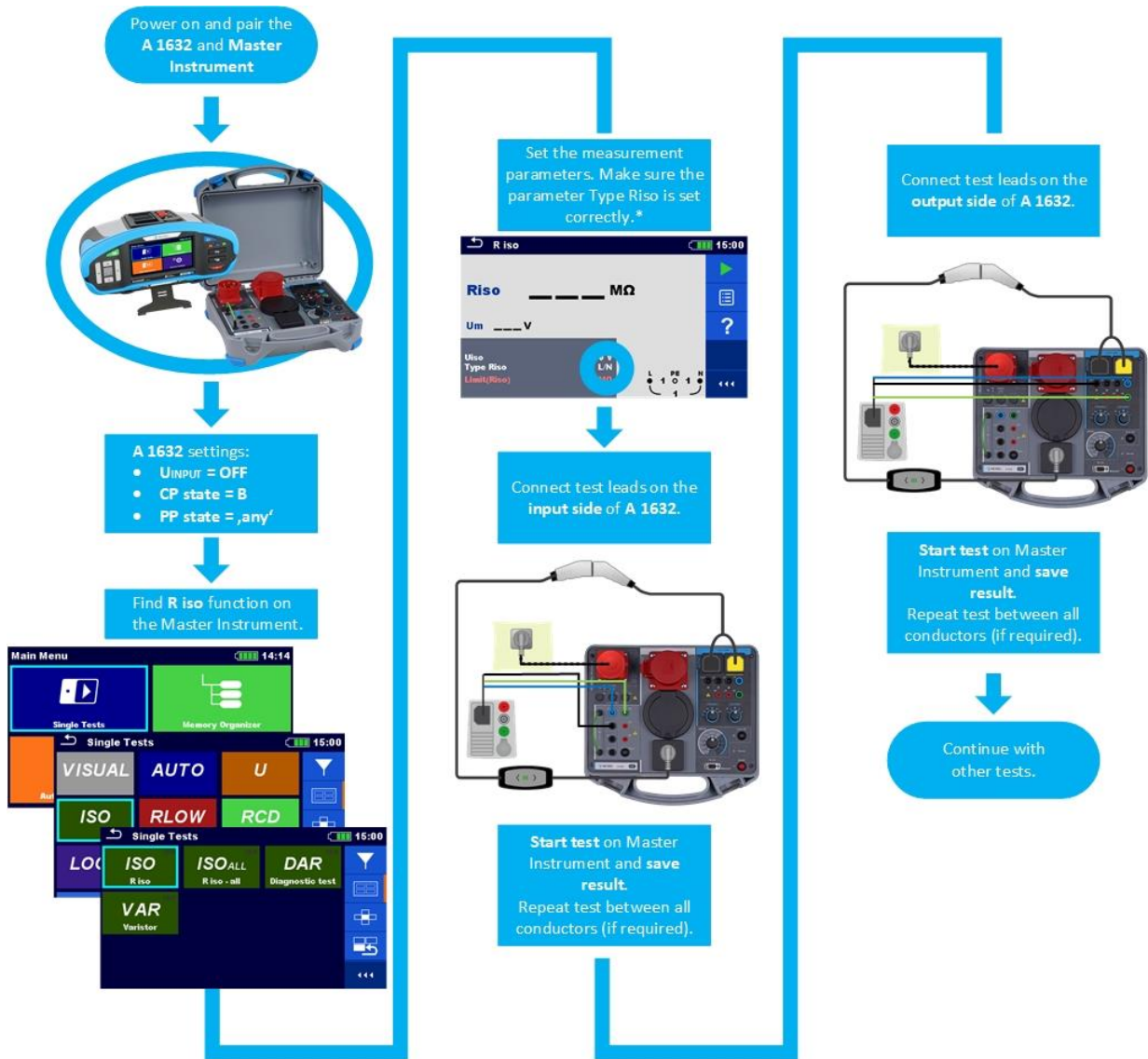

Figure 6.11: Manual continuity measurement procedure on a 1-phase Mode 2 EV cable

6.2.5.2 Insulation measurement (R iso)

The insulation resistance must be measured on the input and output side of cable. In both cases no voltage should be present beforehand. In case other equipment is used as a Master Instrument use the appropriate implemented function. Metrel offers an additional solution for speeding up the isolation resistance testing; the A 1507 3-Phase Active Switch adapter.



* Depending on the Master Instrument, the way parameter Type Riso is handled differs. On MI 3155 it defines between which conductors the measurement will take place. On the MI 3152 it is strictly informative, since MI 3152 can only measure insulation between L and N test leads.

Figure 6.12: Manual insulation measurement procedure on a 1-phase Mode 2 EV cable

6.2.5.3 RCD (IC-CPD / PRCD S+) measurement

The Mode 2 EV charging cable typically comes with a PRCD-S+ or a IC-CPD installed as a protection device. Testing of the IC-CPD integrated into the Mode 2 EV cable is done on the output side of the A 1632 eMobility Analyser. To test, follow the procedure:

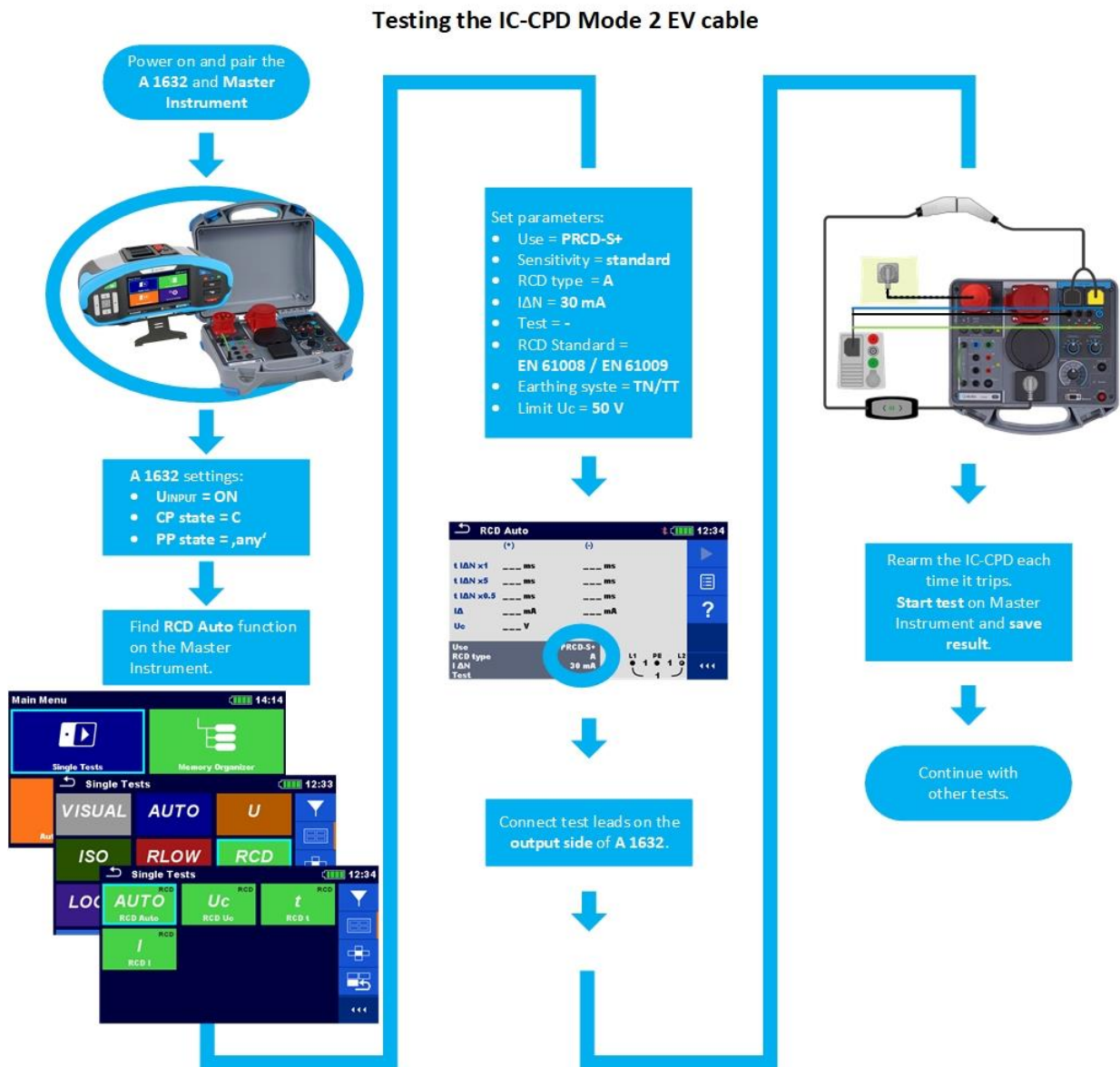

Figure 6.13: Manual IC-CPD measurement procedure on a 1-phase Mode 2 EV cable

6.2.5.4 Leakage current measurement

To measure leakage of the Mode 2 EV cable simply connect it to the A 1632 eMobility Analyser and connect it to the mains. Power the **A 1632** and the leakage current clamps **MD 9272** ON and follow the procedure described below.

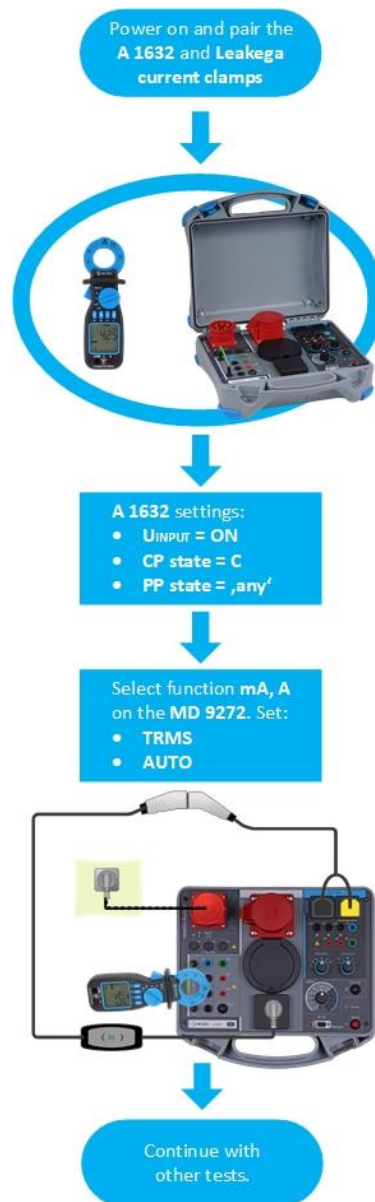

Figure 6.14: Manual leakage measurement procedure on a 1-phase Mode 2 EV cable

Note: No simulation of fault is necessary to check the cable. The leakage current measurement does not get stored anywhere and it should be added to the final report manually or as part of a separate report.

6.3 Mode 3 EV cable testing

Testing of Mode 3 EV cables is done similarly to testing Mode 2 EV cables. As Mode 3 cables do not have internal protective electronics the IC-CPD part is omitted from the tests as is any diagnostic testing via the input and output errors or the CP and PP states on the A 1632 eMobility Analyser. Instead the A 1632 serves only as a tool that enables us to connect measuring leads of a master instrument to both sides of the Mode 3 EV cable.

In case of Mode 3 EV cable continuity, insulation, leakage current and resistance coding tests have to be made. These tests may be done either manually (as explained in this quick guide) or fully automated, providing that the reader has prepared an Auto Sequence to accommodate such testing.

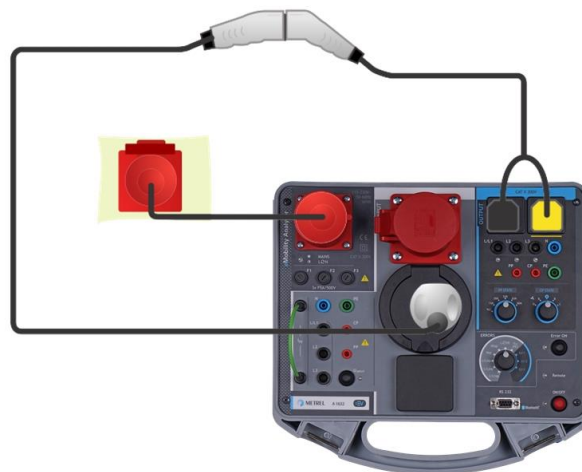

Figure 6.15: 3-Basic Mode 3 EV cable configuration

6.3.1 Manual electrical safety testing of Mode 3 EV cable

6.3.1.1 Continuity measurement (R low 200 mA)

The measurement is done with the Master Instrument on each conductor between the input and the output terminal.

The Mode 3EV cable doesn't have any protective electronic integrated therefore testing it is straightforward. This means that CP, PP error states and the button UINPUT do not have any impact on the measuring procedure. The difference between continuity measurement described in this chapter and chapter 6.2.5.1 is only in the Current parameter on the Master Instrument. For the safe of faster testing it is recommended to set the parameter to standard.

When the continuity test is done on all conductors, regardless whether it is a 1-phase or a 3-phase Mode 3 EV cable, the polarity is also proven or rejected. The procedure described in Figure 6.16 shows how to test the continuity on a 1-phase Mode 3 EV cable. To fully test a 3-phase Mode 3 EV cable simply test the continuity on all 3 phases as well. Additionally it is recommended to test also the continuity of the CP cable to make sure that communication between the EV and EVSE is not impaired.

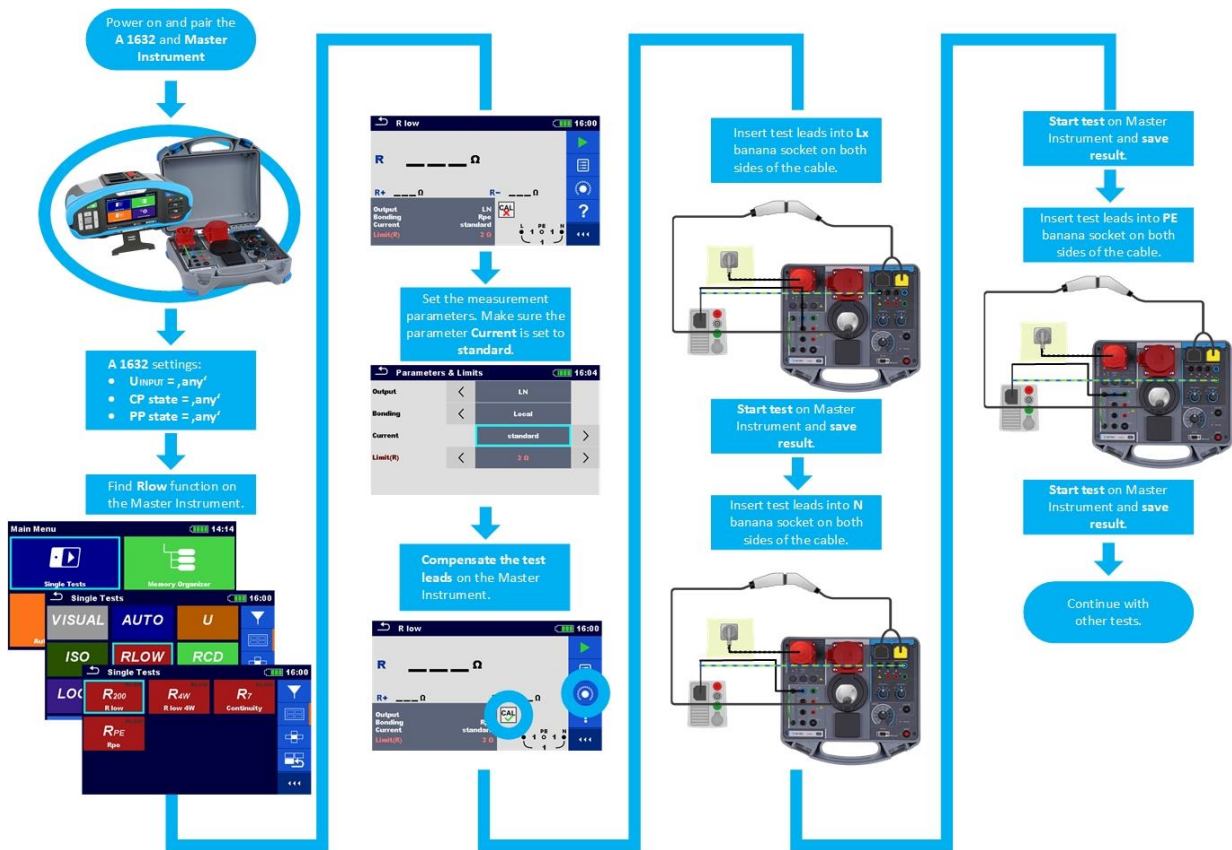

Figure 6.16: Manual continuity measurement procedure on a 3-phase Mode 3 EV cable

6.3.1.2 Insulation measurement (R iso)

Except for the cable used the procedure is the same as explained in chapter 6.2.5.2 Insulation measurement (R iso) and shown in Figure 6.12 of the same chapter. The Mode 3 EV cable should be connected as shown in Figure 6.15.

6.3.1.3 Leakage current measurement

Except for the cable used the procedure is the same as explained in chapter 6.2.5.4 Leakage current measurement and shown in Figure 6.14 of the same chapter. The Mode 3 EV cable should be connected as shown in Figure 6.15.

6.3.1.4 Testing resistance coding for vehicle coupling and plug

The resistance coding of Mode 3 and Mode 2 EV cables is used for determining the maximum current that can flow through the cable while charging the EV. Different values are used for different charging speeds. The list of the values is as follows:

- 1500 Ω for a 13 A Charging cable
- 680 Ω for a 20 A Charging cable
- 220 Ω for a 32 A Charging cable
- 100 Ω for a 63 A Charging cable
- 56 Ω for a 80 A Charging cable

To measure the resistance coding of a cable follow the procedure as shown in Figure 6.17 below.

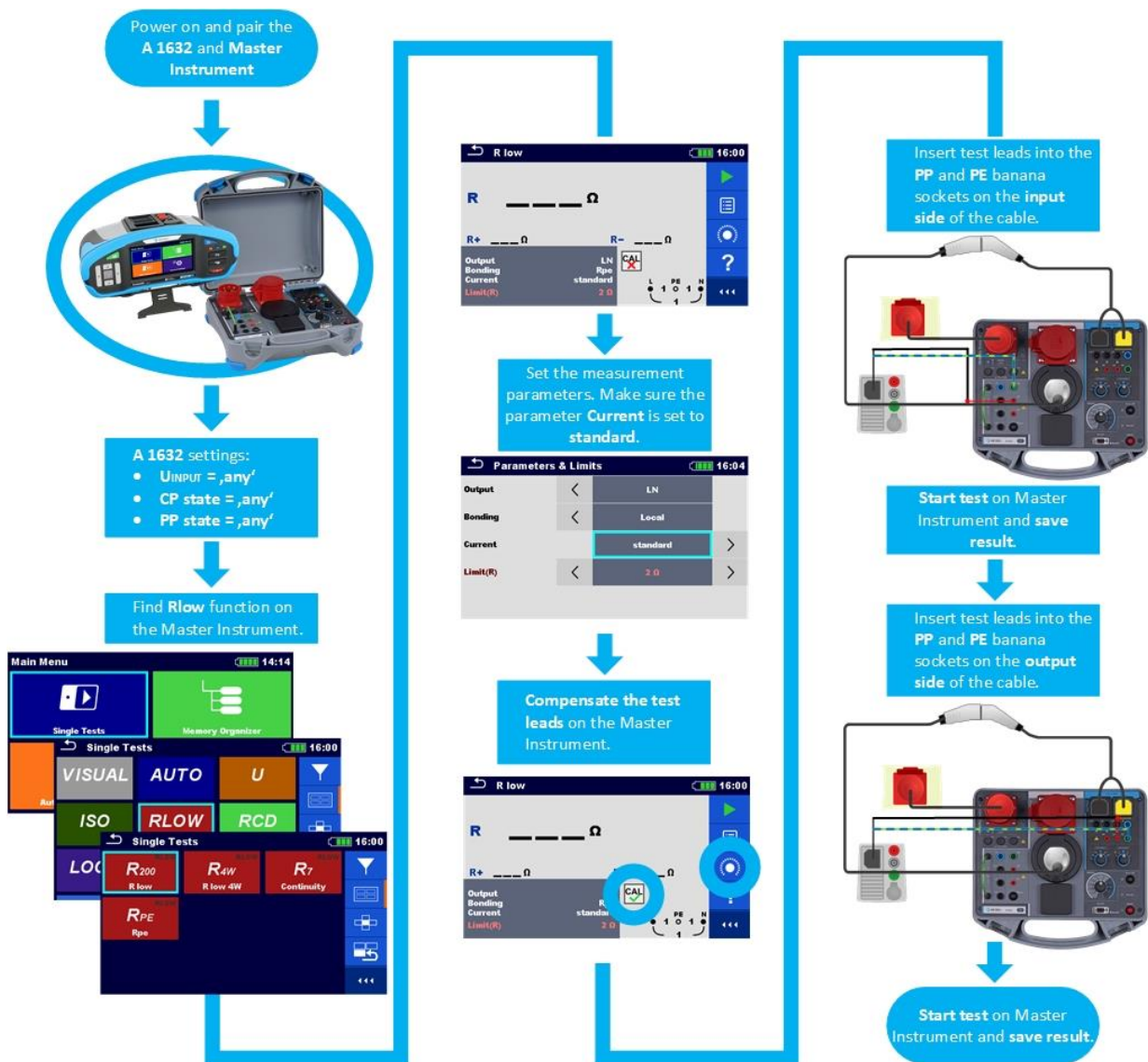

Figure 6.17: Manual resistance coding measurement procedure on a 3-phase Mode 3 EV cable

6.4 Monitoring with the use of A 1631 EV Monitoring cable

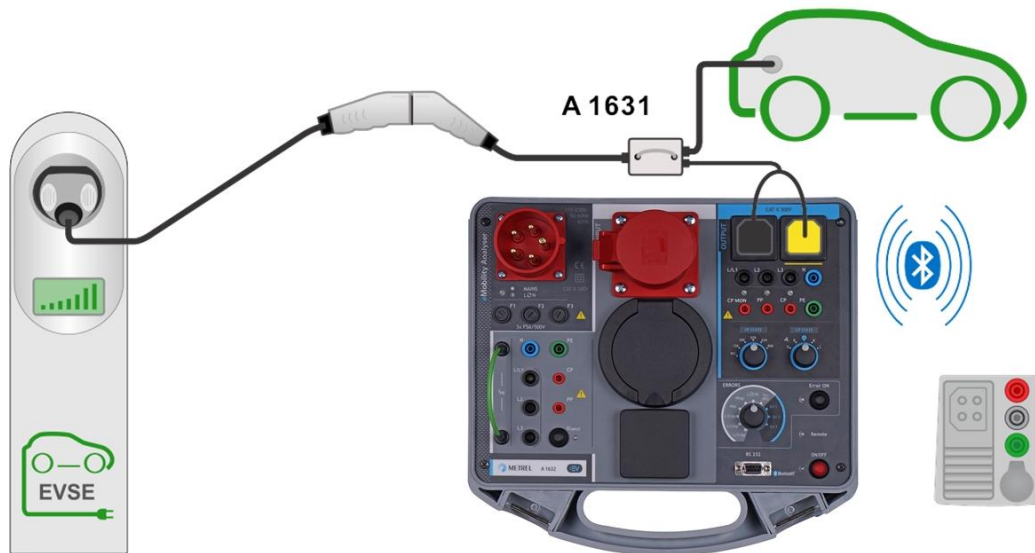

Figure 6.18: 3-Basic monitoring configuration

6.4.1 Monitoring of the charging process

The monitoring of the CP communication and performing electrical safety measurements at the time of charging an EV is in some literature also referred to as the Man-in-the-Middle verification. With the help of an additional adapter, the A 1631 EV Monitoring Cable it is possible to perform verification of the CP low level communication signal, current and other electrical testing, all during the actual charging procedure. The A 1631 is designed in such a way that it only listens to the CP communication without actually influencing it.

Follow the procedure shown in Figure 6.19 to monitor the CP communication between EV and EVSE.

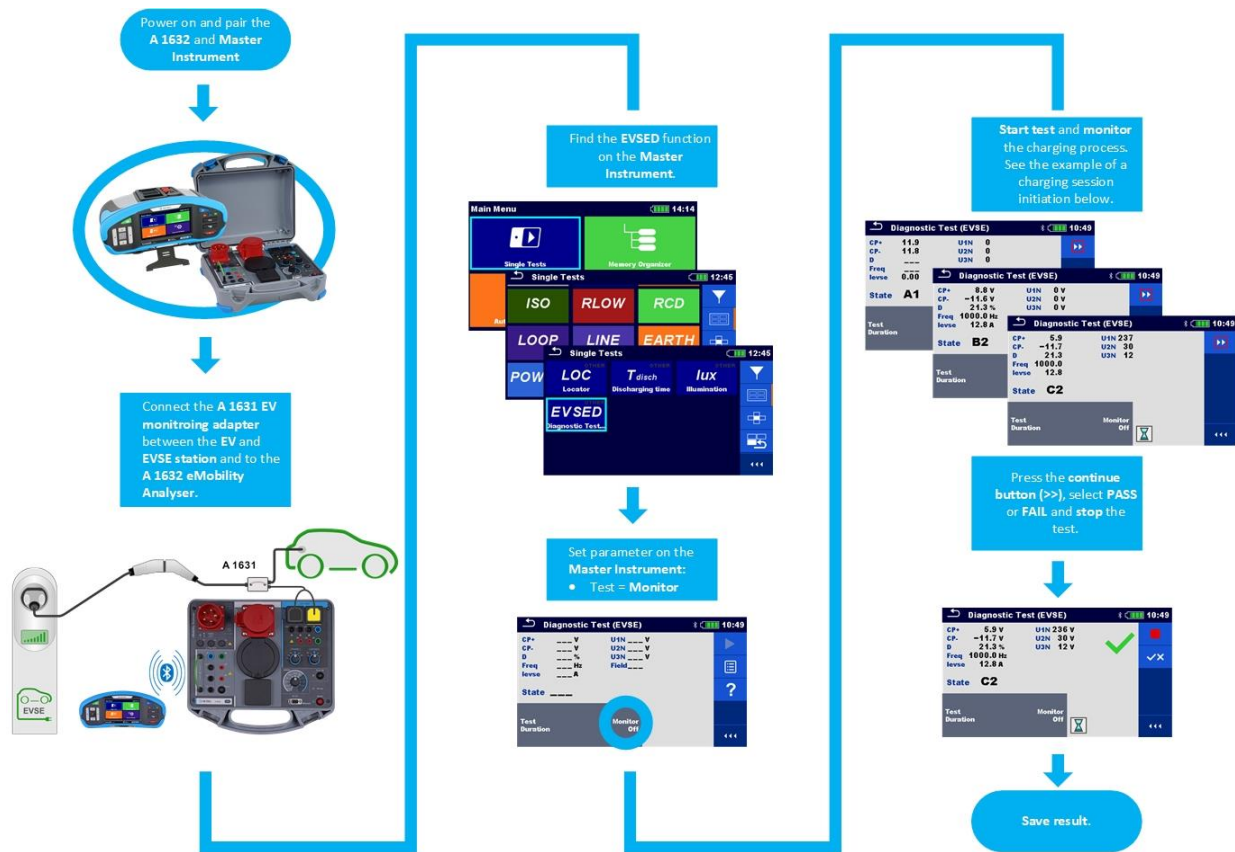

Figure 6.19: CP communication monitoring during EV charging

7 Saving data and reporting

After completing the intended measurements save the Auto Sequence or a series of single tests under the appropriate structure element on the Master Instrument as shown in the picture below.

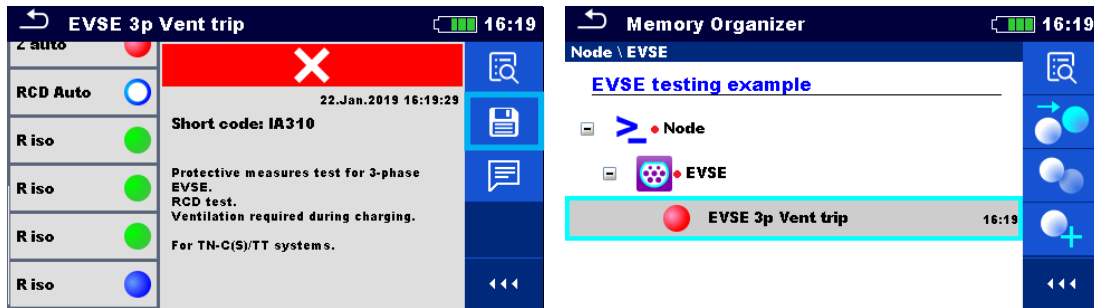

Figure 7.1: Saving the results on the Master Instrument under the EVSE structure object

Now that the data is safely stored we can connect the Master Instrument to a PC running PC SW MESM (Metrel Electrical Safety Manager).

After the data has been downloaded to MESM an EVSE report can be created. Below is a sample of one such report.

ELECTRICAL VEHICLE SUPPLY EQUIPMENT TEST REPORT	
Customer No.: _____	Inspect. rec. No.: _____
Order No.: _____	
GENERAL DATA	
Client: Metrel d.o.o., Ljubljanska cesta 77, SI-1354 Horjul	Contractor: Mina Doberlet, <naslov>
Client's representative: Edvard Reven, Ljubljanska cesta 77, SI-1354 Horjul	Inspector: Janez Guzej, <naslov>
Charging station: Group/model: EVSE - private ID: EVSE Producer: Ebel Year: 2017 Serial No.: _____ No. of sockets: 1	
Report covers: <input type="checkbox"/> New installation <input type="checkbox"/> Service, repair <input checked="" type="checkbox"/> Periodic test	Test in accordance with: <input checked="" type="checkbox"/> EN 61851-1 <input checked="" type="checkbox"/> IEC/EN 60384-8 <input type="checkbox"/> EN 61010-1
Measuring instruments used: Model: M13155 Model: _____ Test date: _____ Serial No.: 17120417 Serial No.: _____	
Attachments: <input checked="" type="checkbox"/> Test results <input type="checkbox"/> Description of faulty equipment <input type="checkbox"/> Checklist <input type="checkbox"/> Other	
Results: <input checked="" type="checkbox"/> No faults found <input type="checkbox"/> Faults found	
Notes:	
SYSTEM	
Earthing system: <input type="checkbox"/> TN-C <input checked="" type="checkbox"/> TN-C-S <input type="checkbox"/> TN-S <input type="checkbox"/> TT <input type="checkbox"/> IT	
Mains: 230 V Public utility: _____ Usom: 230 V From: 50 Hz	
Conductor type: _____ Conductor cross-section: 16 mm ²	
Overcurrent protection <input checked="" type="checkbox"/> RCD EV Type: EV RCD In: 2 A I Δ n: 30 mA	
INSPECTION RESULT, SIGNATURE AND STAMP	
<input checked="" type="checkbox"/> No faults found <input type="checkbox"/> Faults found	Date of next inspection: 11/11/2018 Inspection label applied: <input checked="" type="checkbox"/> YES <input type="checkbox"/> NO
Client: <input checked="" type="checkbox"/> Electrical vehicle supply equipment fully accepted according to handover report <input checked="" type="checkbox"/> Status report received	Operator: Electrical vehicle supply equipment meets accepted engineering standards <input checked="" type="checkbox"/> YES <input type="checkbox"/> NO
Location: Horjul Date: 17/11/2017 Signature: _____	Location: Horjul Date: 17/11/2017 Signature: _____
<input type="checkbox"/> Enclosures	
Page 1 / 4	Page 2 / 4

Figure 7.2: EVSE report example in MESM (part 1)

Customer No.: Inspect. rec. No.: Order No.:		
ELECTRICAL VEHICLE SUPPLY EQUIPMENT TEST REPORT		
Uln: 223 V Ulpe: 223 V Umpe: 0 V Freq: 50.0 Hz	Uln: -10 % Ulpe: 10 % Ulpe: 253 V Umpe: 0 V Umpe: 10 V	DateTime: 17/11/2017 14:29:34 System: 1-phase Linal type: % Earthing system: TN/TT Nominal voltage: 230 V
Z auto EVSE Pass		
Uln: 223 V ΔU: 0.0 % Z (LPE): 0.73 Ω Z (LN): 0.71 Ω Ipsc (LN): 324 A Ipsc (LPE): 314 A Uc: 0.0 V Zlpe: 0.77 Ω	ΔU: 3.5 % Ipsc (LN): 100 A Ipsc (LPE): 100 A Uc: 25 V	DateTime: 17/11/2017 14:29:43 Protection: TN/rd Fuse Type: C Fuse I: 10 A Fuse t: 0.4 s Isc factor: 1 RCD type: A IΔN: 30 mA Selectivity: G Phase: L3 I test: Low
RCD Auto EVSE Pass		
IΔN x1 (+): 9.6 ms IΔN x1 (-): 9.1 ms IΔN x5 (+): 9.2 ms IΔN x5 (-): 7.9 ms IΔN x0.5 (+): >300 ms IΔN x0.5 (-): >300 ms IΔ (+): 28.5 mA IΔ (-): 27.9 mA Uc: 0.3 V	Uc: 25 V	DateTime: 17/11/2017 14:32:49 Use: fixed Selectivity: G RCD type: A IΔN: 30 mA Test: L3/PE RCD Standard: EN 61008 / EN 61009 Earthing system: TN/TT
R iso EVSE Pass		
Riso: >999 MΩ Um: 525 V	Riso: 1 MΩ	DateTime: 17/11/2017 14:34:05 Uliso: 500 V Type Riso: L3/PE
R iso EVSE Pass		
Riso: >999 MΩ Um: 525 V	Riso: 1 MΩ	DateTime: 17/11/2017 14:34:11 Uliso: 500 V Type Riso: L2/PE
R iso EVSE Pass		
Riso: >999 MΩ Um: 525 V	Riso: 1 MΩ	DateTime: 17/11/2017 14:34:18 Uliso: 500 V Type Riso: L1/PE
R iso EVSE Nothing		
Riso: >999 MΩ Um: 525 V	Riso: Off	DateTime: 17/11/2017 14:34:27 Uliso: 500 V Type Riso: N/PE
Signature: _____	Customer: _____	Operator: _____
Page: 3 / 4		

Customer No.: Inspect. rec. No.: Order No.:		
ELECTRICAL VEHICLE SUPPLY EQUIPMENT TEST REPORT		
VISUAL AND FUNCTIONAL INSPECTION		
COMMENTS		
Signature: _____	Customer: _____	Operator: _____
Page: 4 / 4		

Figure 7.3: EVSE report example in MESM (part 2)

For more detailed information regarding downloading of test results from the Master Instrument to PC SW MESM and EVSE report creation please refer to the MESM user manual. The MESM user manual is part of MESM SW and can be viewed via the **Help** menu as seen from the picture below.

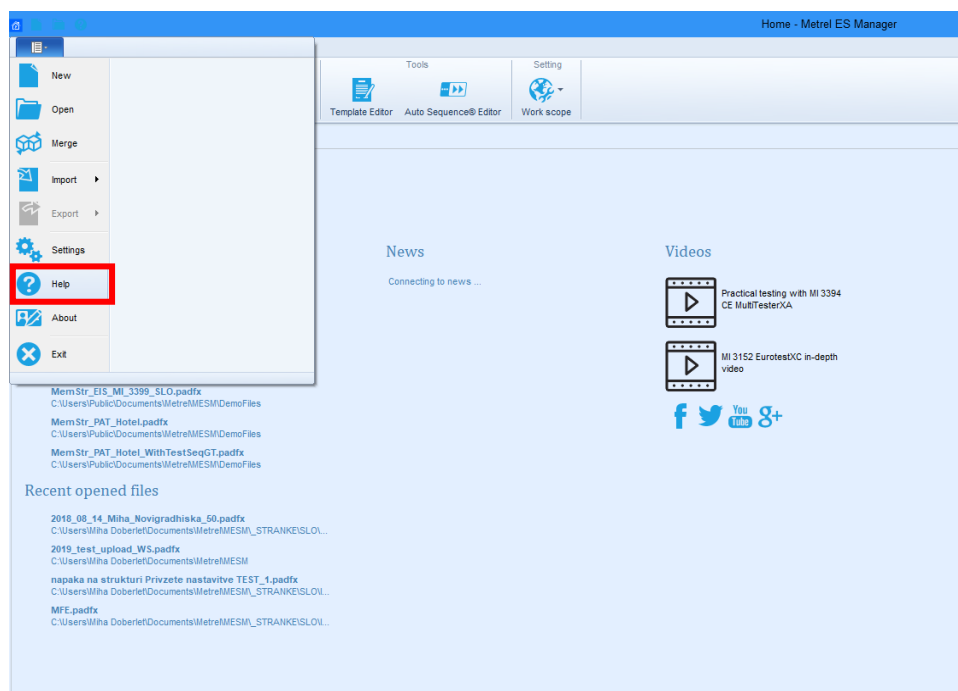

Figure 7.4: Starting MESM Help

The MESM user manual will open in a PDF reader.

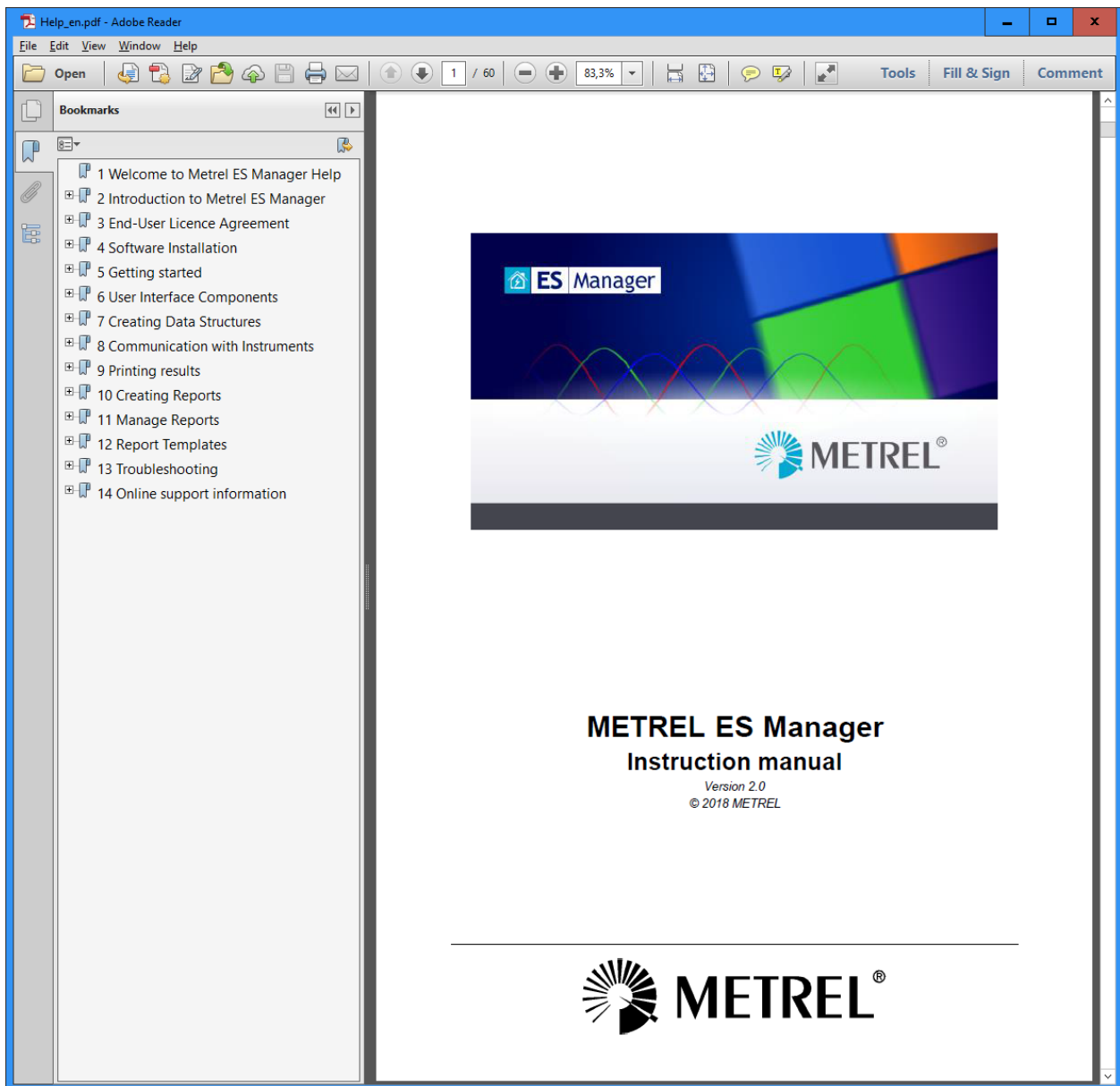

Figure 7.5: MESM Help

8 Abbreviations

CEE	Central and Eastern Europe plug or inlet
CP	Control Pilot
EN	European Norm
EV	Electrical Vehicle
EVSE	Electrical Vehicle Supply Equipment (EVSE),
HPC	High Power Charging
I	Current
ICCB	In-Cable Control Box
IC-CPD	In-Cable Control and Protective Device
IEC	International Electrotechnical Commission
IT	Isolation-Terra earthing system
$I\Delta N$	Nominal current
L	Phase conductor
L1	Phase 1 conductor
$L1_{op}$	Phase 1 conductor opened
L2	Phase 2 conductor
$L2_{op}$	Phase 2 conductor opened
L3	Phase 3 conductor
$L3_{op}$	Phase 3 conductor opened
L_{op}	Phase conductor opened
Lx	Any phase conductor
MESM	Metrel Electrical Safety Manager
N	Neutral conductor
N_{op}	Neutral conductor opened
PE	Protective Earth
PE_{op}	Protective Earth conductor opened
PP	Proximity Pilot
PRCD	Portable Residual Current Device
PRCD-S+	Portable Residual Current Device with type S+ protection
PWM	Pulse Width Modulation
R ISO	Insulation resistance
RCD	Residual Current Device
TN	Terra-Network earthing system
TT	Terra-Terra earthing system
U_c	Contact Voltage
U_{EXT}	External voltage
U_{INPUT}	Input voltage
U_o	Nominal voltage
Z_s	Loop impedance measured with low current

9 Document versions

Version number	Date of issue	Changes
Version 1.1.3	18. 02.2019	First version.
Version 1.1.4	19.09.2019	Added explanation and support for EV monitoring.

10 Sources

- [1] IEC 61851-1 Ed. 3 Electric vehicle conductive charging system Part 1: General requirements
- [2] eCheck directive (Richtlinie zum E-CHECK E-Mobilität), © 2017 ArGe Medien im ZVEH
- [3] https://en.wikipedia.org/wiki/IEC_62196
- [4] https://en.wikipedia.org/wiki/Combined_Charging_System
- [5] <https://en.wikipedia.org/wiki/CHAdeMO>
- [6] <https://www.phoenixcontact-emobility.com/en/products/charging-systems/vehicle-inlets>
- [7] https://www.bals.com/downloads/kataloge-prospekte/emboile_charging_cables_en.pdf
- [8] <https://chargedevs.com/features/state-ev-charging-more-questions-answers/>
- [9] <https://www.jetcharge.com.au/vehicle-plug-types/>
- [10] <http://rema-ev.com/wp-content/uploads/2016/09/CCS-1-Inlet-Datasheet-201604.pdf>