



# PHANTOM VEO4K 990 VEO4K 590

HIGH-SPEED CAMERA

9.4 Mpx resolution 4096 x 2304  
Up-to 938 fps (990); 540 fps (590)  
L and S body styles

## FEATURES & BENEFITS

### HIGHEST RESOLUTION VEO

VEO4K cameras combine two platforms, the **compact and versatile** VEO and the Flex4K for high-speed imaging with the **ultimate in image quality and pixel resolution**. Application examples include object tracking over a large area, subjects that require high magnification, and advanced motion analysis techniques that require the precision offered by a higher pixel count.

### EXTREME CONFIGURABILITY

- \* **Two sensor modes:** VEO4K employs a proprietary **global shutter** sensor that can be switched to **rolling shutter** mode for increased dynamic range. VEO4K-RLS models are also available for rolling-shutter only requirements.
- **L-model** is for basic, software based imaging in a lab or office environment
- **S-model** provides additional signals, on-camera controls for untethered and remote recording, ruggedized connectors and compatibility with removable CFast 2.0 storage media.

FRAME RATES & EXPOSURE		
Top FPS at Max Resolution	990: 938	590: 540
Maximum FPS	990: 64,300	590: 54,600
Minimum FPS	24	
CAR Increments	2048 x 4	
Minimum Exposure	5 $\mu$ s Standard	
Electronic Shutter	VEO4K models include global shutter (GS) and rolling shutter (RS) modes by default. VEO4K-RLS models are also available for rolling-shutter only.	
PIV Features	Only available in GS mode. Enable shutter-off mode for straddle time of 3.7 $\mu$ s at max resolution, Supports Burst Mode	
Exposure Features	Overexposure indication over video and in PCC	

IMAGING		
Sensor Type	CMOS (RS mode uses Correlated Double Sampling)	
Maximum Resolution	4096 x 2304	
Bit Depth	12-bit	
Pixel Size	6.75 $\mu$ m	
Sensor Size	27.6 x 15.6; 31.7 mm diagonal	
ISO Daylight (12232 STD)	GS: Mono 2,500; Color 640	RS: Mono 1,000; Color 320
ISO Tungsten (12232 STD)	GS: Mono 5,000; Color 640	RS: Mono 2,000; Color 320
Exposure Index	Recommended EI Range 4,000-8,000 Mono; 800-1000 Color (both Global and Rolling)	
Dynamic Range	GS: 54.8 dB (9 stops)	RS: 71.6 dB (12 stops)
Readout Noise	GS: 31 e-	RS: 9.6 e-

## FRAME RATE CHART

Table provides examples of common resolutions and frame rates. The record times shown are for 72GB RAM at the frame rate shown. Duration will be 1/2 the time for 36GB RAM.

Maximum Frame Rate - FPS; (72GB Record time - Sec)		
Resolution (H x V)	VEO 990	VEO 590
4096 x 2304	938 (5.5)	530 (10)
4096 x 2160	1,000 (5.6)	570 (10)
4096 x 2048	1,050 (5.8)	600 (10)
4096 x 1152	1,850 (5.8)	1,070 (10)
4096 x 1080	1,970 (5.8)	1,140 (10)
4096 x 720	2,930 (5.8)	1,700 (10)
4096 x 360	5,660 (6)	3,330 (10)
4096 x 8	64,300 (10)	54,600 (12)
2048 x 2048	1,050 (11)	600 (10)
2048 x 1152	1,850 (11)	1,070 (20)
2048 x 1080	1,970 (11)	1,140 (20)
2048 x 240	8,220 (12)	4,900 (20)
2048 x 8	64,300 (21)	54,600 (25)



### CONNECTIVITY & SIGNALS

Ethernet	Gigabit Standard, 10Gb Optional		
Timecode	IRIG-B Modulated and Un-modulated		
Port Descriptions		<b>S-model</b>	<b>L-model</b>
	Ethernet	Fischer 8-pin	RJ45
	Power	Fischer 6-pin	Fischer 6-pin
	Range Data	Fischer 8-pin	N/A
	USB	Yes for WiFi dongle	N/A
	Video output	3G-SDI (2 ports), HDMI	3G-SDI (1 port), HDMI
	Dedicated BNC	Trigger, Timecode-in, 3G-SDI	Trigger, Timecode-in
	Programmable I/O BNC	4 ports	2 ports
I/O Signals	Programmable I/O for Fsync, Strobe, Ready, Timecode-out, Event, Memgate, Pretrigger. Assign and define signals in PCC		
Hardware Trigger	Dedicated BNC		
Software Trigger	Trigger button (S-model); via Ethernet		
Synchronization	External Sync via FSync or IRIG Timecode		
Recording Features	Burst mode (GS mode), Continuous recording & AutoSave to CFAST (S-model)		
Video Output	3G-SDI via BNC (rear, S-model only), Din and Micro HDMI type D port (front) <i>Cameras prior to 2021 had HDMI type A port</i>		
Accessory Power	4-pin Hirose (front) for 12V monitors up to 1 Amp		

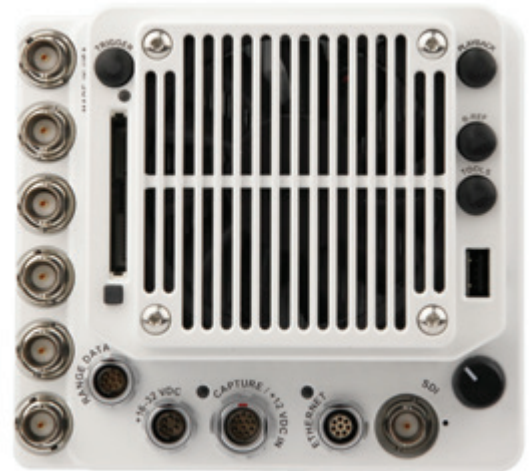

VE0 S-model (Top),  
L-model (Bottom)

### CONTROL

Software & OS	Phantom PCC (Windows); SDK also available with MatLab and LabView drivers
On-camera Controls	S-models only. Access menu system with encoder, viewed on video monitor. Buttons for trigger, play and save – Color indicates current camera state
Primary File Format	Phantom Cine RAW (.cine)
Alternative File Formats	Easily convert to formats including .mp4, Apple ProRes .mov, .avi, Tiff, JPG, DNG and many more using PCC. Cine files are directly compatible with many major video editing and motion analysis programs
Software Feature Highlights	Continuous Recording for automated workflows, Integrated Data Acquisition (NI-DAQ), support for DIC Calibration with Sync-Snapshot menu, advanced Image Tools including Crop & Resample, Tone Curves, Filters and more

## MEMORY & STORAGE

RAM Buffer	36GB, 72GB RAM options
Multi-Cine	Up-to 64 Partitions
Non-Volatile Media	VE0 S-model supports CFAST 2.0 (NTFS format) 80 MB/s Cine Raw file transfer rate from RAM

## MECHANICAL

Housing Variants	L-model and S-model variants
Size	L-Model: 5 X 5 X 6" (12.7 x 12.7 x 15 cm); S-Model: 5 x 5.5 x 6" (12.7 x 14 x 15 cm)
Weight	L-Model: 6 lbs (2.7 kg); S-Model: 6.5 lbs (3 kg)
Lens Mounts	F-Mount standard (aperture support for Nikon G-style lenses). Also available: Canon EF (with electronic focus and iris control), PL, C-mount. Optional OLPF is available for color cameras.
Mounting Points	Standard 1/4x20" mounting points on bottom. Top, bottom and side are compatible with Cameo cheese plate for added mounting points, riser, and custom handle
Internal Shutter	Standard, for remote black references
Cooling	Active cooling. Quiet mode disables fans during capture

## GLOBAL SUPPORT NETWORK

The Phantom VE0 product line is supported by Vision Research's Global Service and Support network, offering PhantomCare Performance Services from multiple sites around the globe. Maximize the value of your Phantom camera with a selection of professional services from which to choose.

Learn more about our service offering at [www.phantomhighspeed.com/Service-Support](http://www.phantomhighspeed.com/Service-Support)

## POWER

AC Power	100-240 VAC, 80W power supply included
Voltage Range	16-32VDC Primary; Secondary Power down to 12VDC via 12-pin capture port (S-models only)
Power Consumption	65W typical
Battery Options	S-model includes 12V input for compatibility with common 14.4V batteries. V-Lock and Gold-mount VE0 side-mounts are available for VE0-S cameras

## ENVIRONMENTAL

Operating Temperature	-10 to +50°C
Storage Temperature	-20 to +70°C
Operational Shock	MIL-STD-202G Method 213-B. Rated 30G with shutter; 100G without; sawtooth wave, 11ms, +/- 10 pulses all axes
Operational Vibration	MIL-STD-202G Method 214-A. Rated 12Grms; Figure 2A-1, Test Condition D, 15 min per axis
Regulatory	Made in the USA CE Emissions – CE Compliant EN 61326-1 CE Immunity – CE Compliant EN 61326-1 FCC – CFR 47, Part 15, Subpart B & ICES-0003, Class A KC Emissions – KC Compliant KC Immunity – KC Compliant Safety - IEC 60950-1

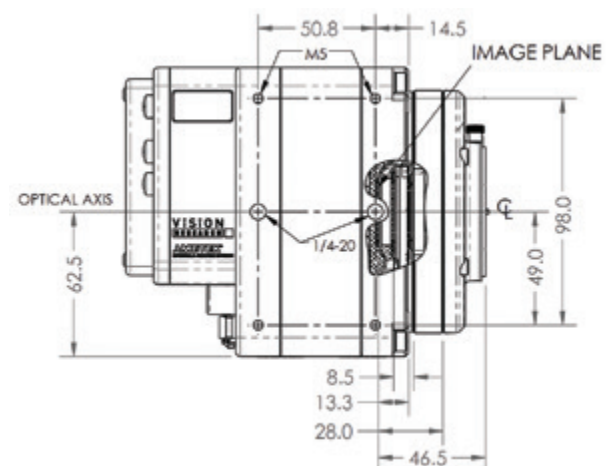

## ABOUT VISION RESEARCH

Focused. Since 1950, Vision Research has been designing, and manufacturing high-speed cameras. Our single focus is to invent, build, and support the most advanced cameras possible.

**ViSiON**  
RESEARCH

**AMETEK**<sup>®</sup>  
MATERIALS ANALYSIS DIVISION

100 Dey Road  
Wayne, NJ 07470 USA  
+1.973.696.4500